

hup![®]
The better way to build



A Building Revolution from Ultraframe

Specification Guide | Version 33 | 03.26



Contents

Summary of specification steps

This guide is designed to give step by step guidance to specify the hup! building system, resulting in completion of a simple order/quote form.

- Introduction 4**
- Order form 6**
- Base Options / Details 9**
- Wall Specification 13**
- Variable Corners 14**
- Wall Finishes 18**
- hup! on Existing Dwarf Walls 34**
- Wall Specification 37**
- Datums and Roof Sizes 43**
- Structural Stability 56**
- Gable Frames 59**
- Frequently Asked Questions 61**
- Order Confirmation Reports 63**

Contact

Customer Service
 01200 452916
 csi@ultraframe.co.uk

Quotations
 01200 452901
 quotes@ultraframe.co.uk

Marketing Support
 01200 452919
 marketing@ultraframe.co.uk

Technical Support
 01200 414607
 techsupport@ultraframe.co.uk



Introduction

Welcome to the hup! Specification Guide

Using the latest Ultrapanel technology and pre-manufactured to the required specifications, the hup! system is quick to build, hassle free and requires minimal cutting or drilling on site. The hup! system has been designed to be installed by trained conservatory fitters or builders and is fully compliant with the latest Building Regulations with a U-Value of 0.17W/m²K for the walls, 0.15 W/m²K for solid roofs, and 1.4W/m²K for glazed roofs. The product is compatible with hup! Brick Slips and any other wall finishes available on the market.

Below is a typical Tiled Roof lean-to extension.

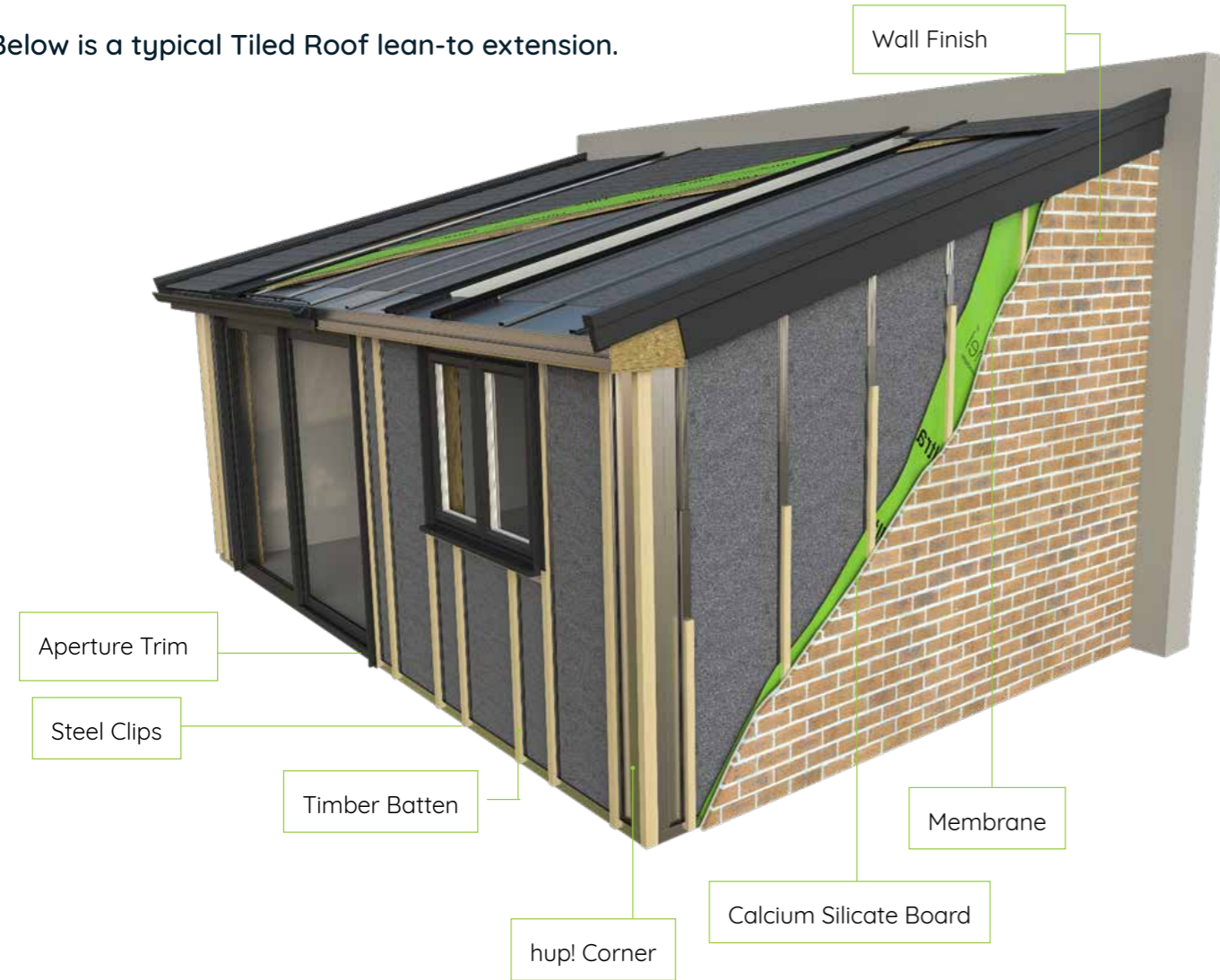

hup! Base

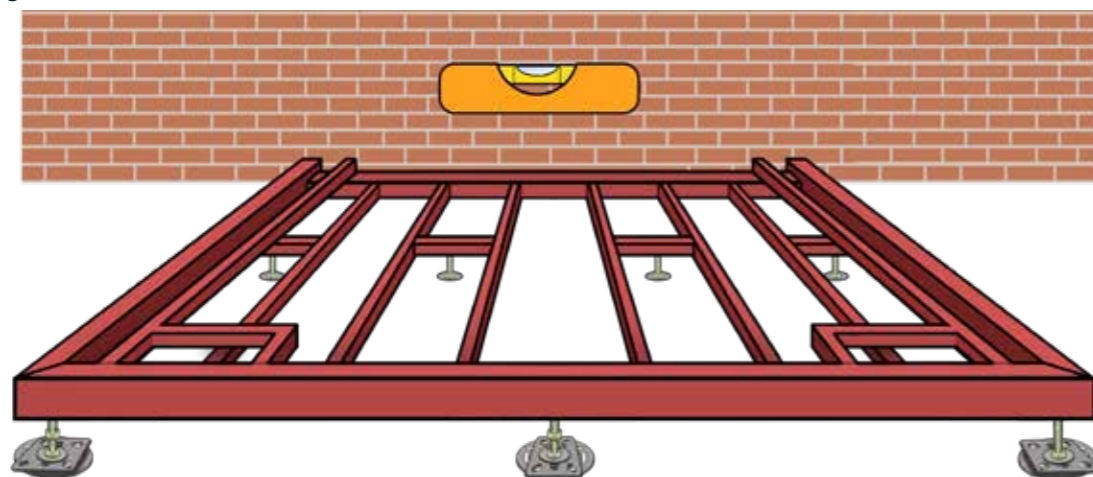

hup! wall

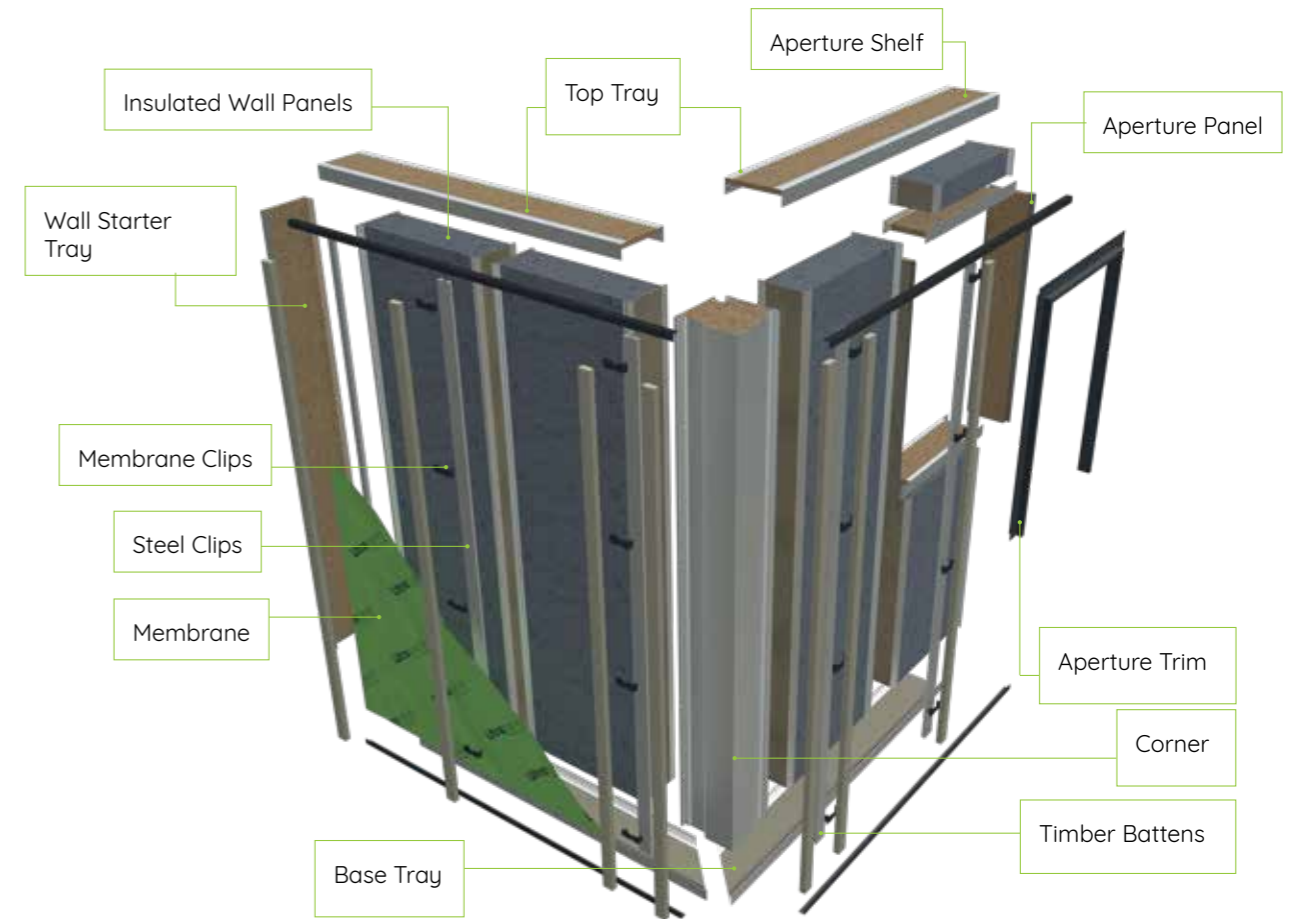

hup! walls, when combined with the choice of one of four different roofing systems, deliver a lightweight yet robust structural solution which can be built and made watertight in a fraction of the time it takes to build the equivalent structure using standard construction methods. hup! Base which is compatible with pads or ground screws makes the installation even faster and cleaner on site.

Four hup! Roofs



Glass Roof

Hybrid Roof

Tiled Roof

Flat Roof

Steel Framework

The hup! Base steel framework consists of an outer edge beam and an inner edge beam to support the base tray. The inner edge beam is not present below door openings and there is no base tray to support. Intrusions can also be accommodated but must be clearly indicated on the order form allowing for clearance around the obstruction. Floor joists run depending on the size & orientation of the building.

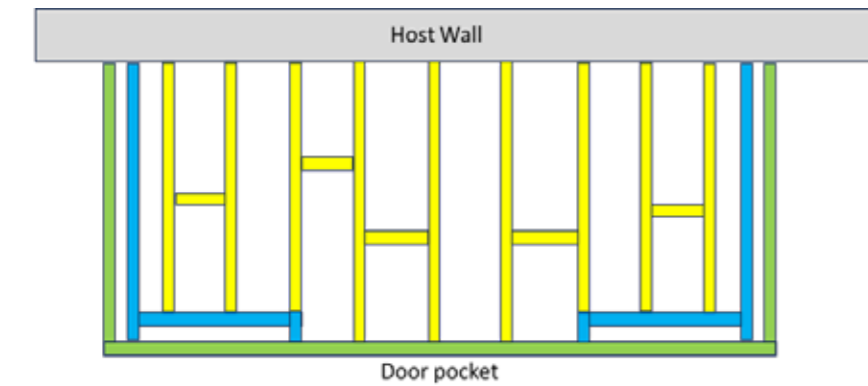

- Outer Edge beam to support hup wall and frames
- Inner Edge beam to support the hup wall rear edge
- Steel Joists



Inner edge beam return to door pocket



Intrusions for pipework

A pad / screw plan will be provided on order or on request that you may give to your ground screw company showing where the fixings for the pads will be on your hup! Base. Example plan below.

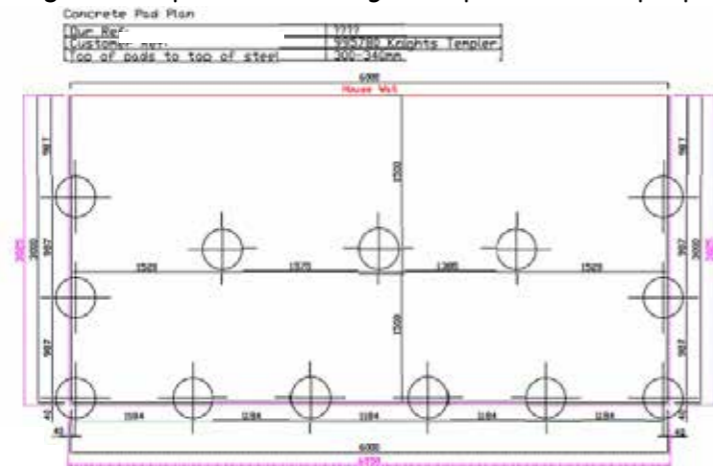

Skirt

Choose from 4 brick colours with sand, grey or red mortar. The skirt is delivered in panels with pre-pointed bricks. At the corners and where the panels join bricks will need to be fixed and pointed. Spare bricks and mortar are provided. Plain skirts can also be provided however these are unsuitable for render as it is not recommended to render below DPC due to the risk of the render blowing if the board gets damp. We would recommend you paint a plain skirt or use a suitable cladding. Render board skirts can be provided on request, but are not advised in most situations.



335 Red Multi



400 Smooth Red



688 Rustic Buff Multi



700 Smooth Anthracite

Traditional Bases

As an alternative to the hup! Base, conventional strip foundations can be used. There is no need for a cavity between the two brick skins at the edge of the base with hup!. This is because ventilation (drainage) is outside the base behind the wall finishes.

If your base requires the hup! wall to be fixed to the blockwork (as shown in the insulated raft foundation (page 12) ensure that the specification of the block is 7.3N/mm². *

Please refer to Building Regulations to determine the right style and depth of base required for the ground conditions on site. Always consult with your local authority on ground conditions and whether a radon or methane barrier is required so you can specify the correct base for the site.

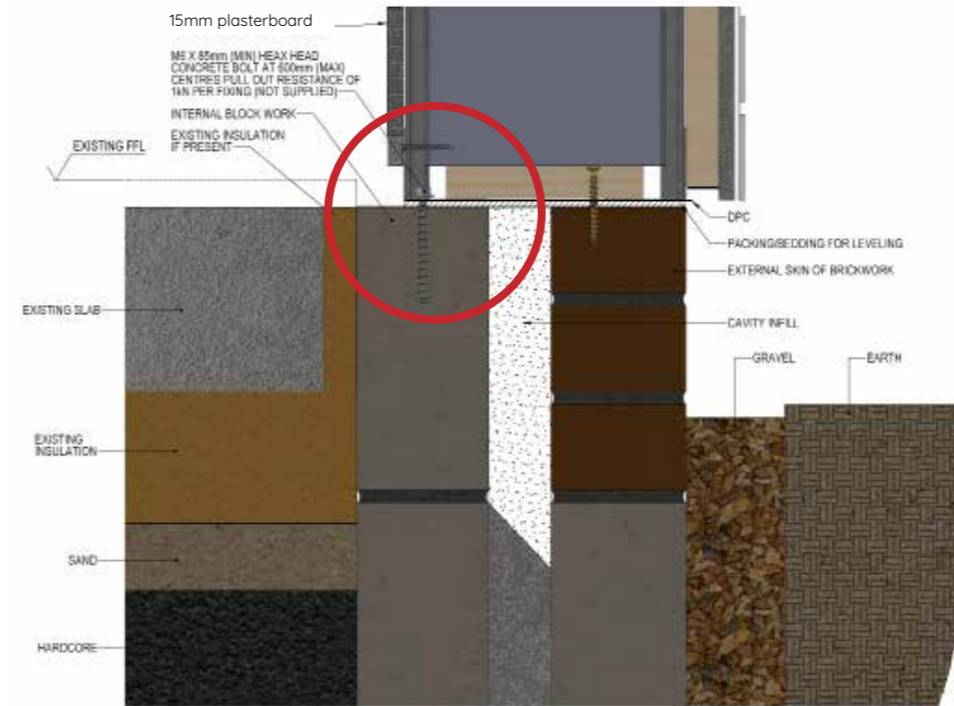

250mm Cavity Wall Base Detail (standard)

We recommend that the base tray is fixed to the concrete slab/ outer leaf and sits over the slab or internal leaf of blockwork.

Standard base tray accommodates base cavity wall up to 275mm*



300mm Cavity Wall Base Detail (extended)

When installing hup! on to an existing foundation, it is important to ensure there is level surface on which to sit the base tray.

Simply point the cavity so the surface is level from the external leaf of brick to the inner leaf of blockwork. The base tray then fixes firmly and level.

To ensure you get this extended base tray, specify 300mm cavity wall when you order.

300mm base tray accommodates base cavity wall from 276mm* to 327mm*

*Please ensure that the cavity is filled to prevent the block from breaking. If fixing to a base cavity wall with a suspended timber floor, please contact Ultraframe Technical department. Do not attempt to fix to hollow brickwork.

Other Base Details

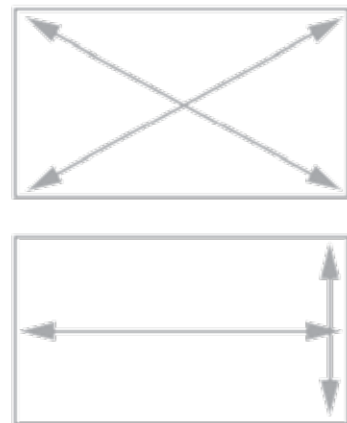
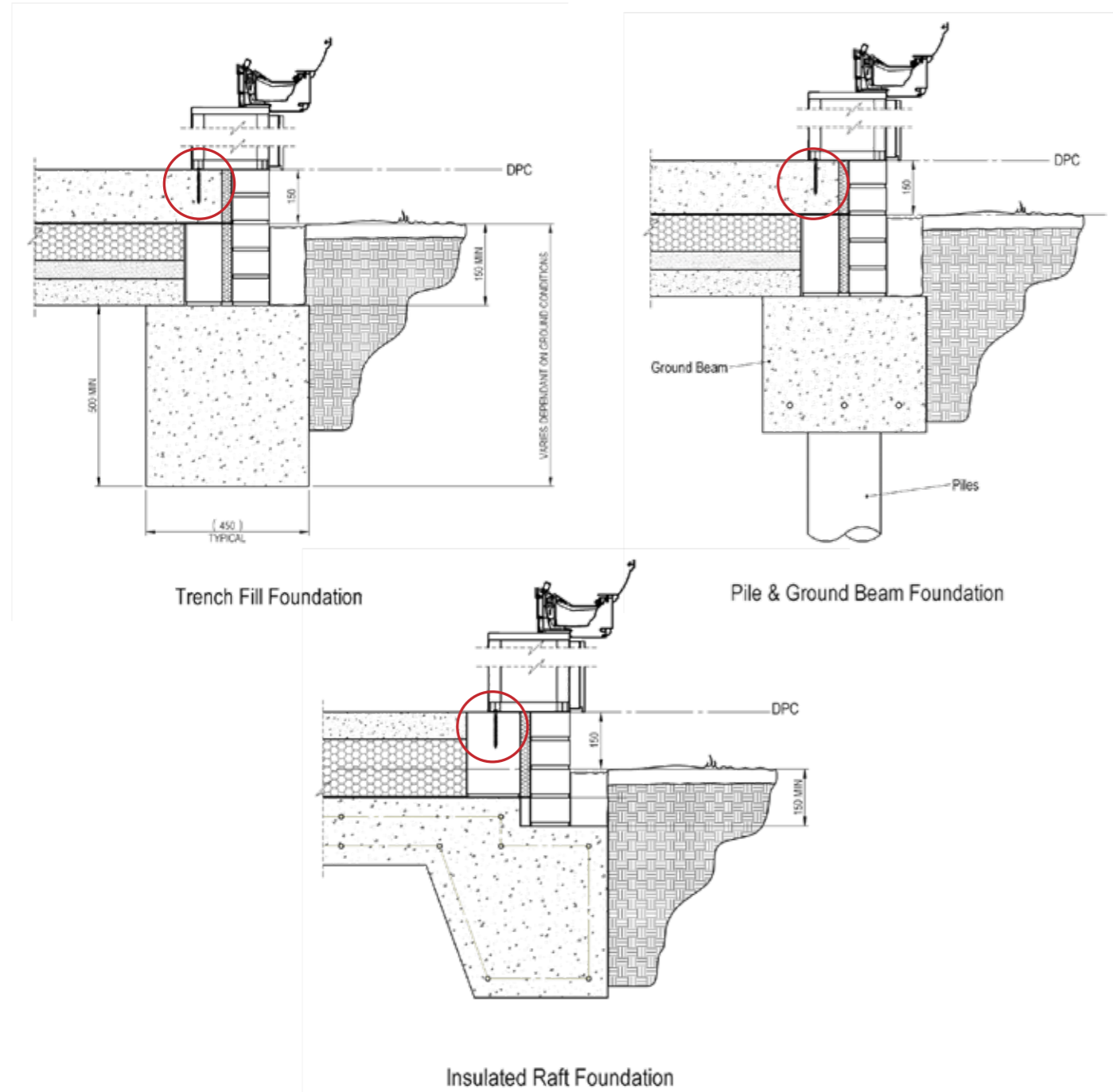

Required Base Tolerances

Measure diagonals to check that the base is square. The check measurement is provided in the paperwork. Acceptable deviation is: +/- 10mm.

Measure lengths of base. Acceptable deviation is: +/-30mm overall on width and +/-15mm on projection.

Wall Thickness and U-Values

Building Regulations requirements for walls

New Building Regulations specify that walls should have a U-Value of 0.18W/m²K. To achieve this value in traditional brick and block construction, the width of the cavity wall will increase from 300mm to 350mm. This size is increased further with the addition of dot and dab plasterboard on the inside (325mm and 375mm respectively). The hup! wall system achieves a U-Value of 0.17W/m²K and only has a width of 227mm.

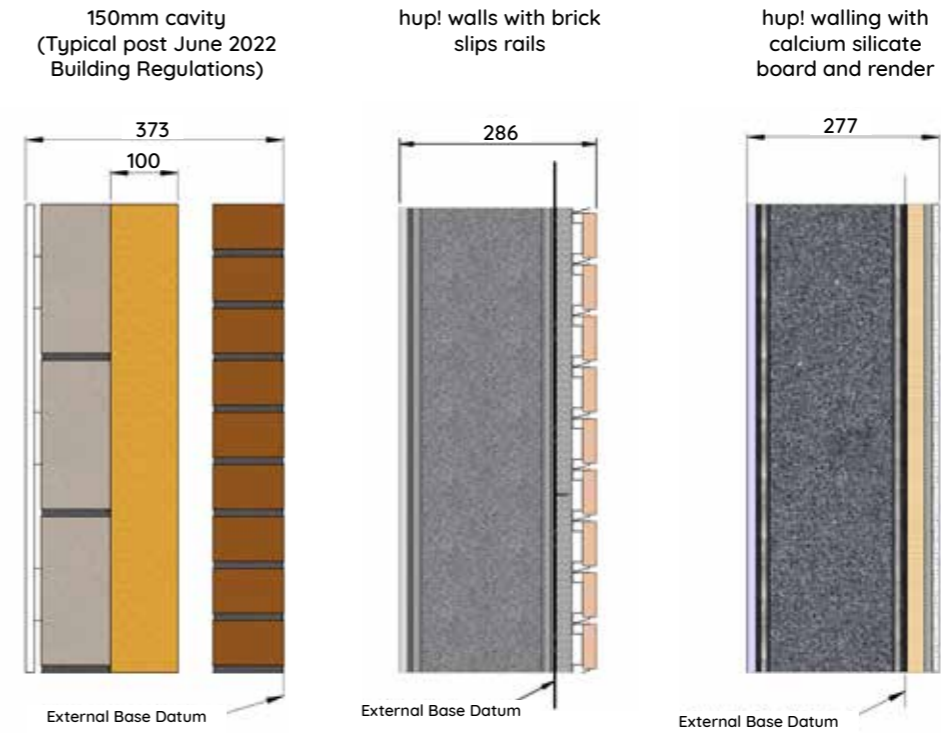

Footprints (Internal & External)

Below is a comparison between typical builds using traditional brick methods above and hup!. The example shown is for a 3000mm x 3000mm external finished wall.

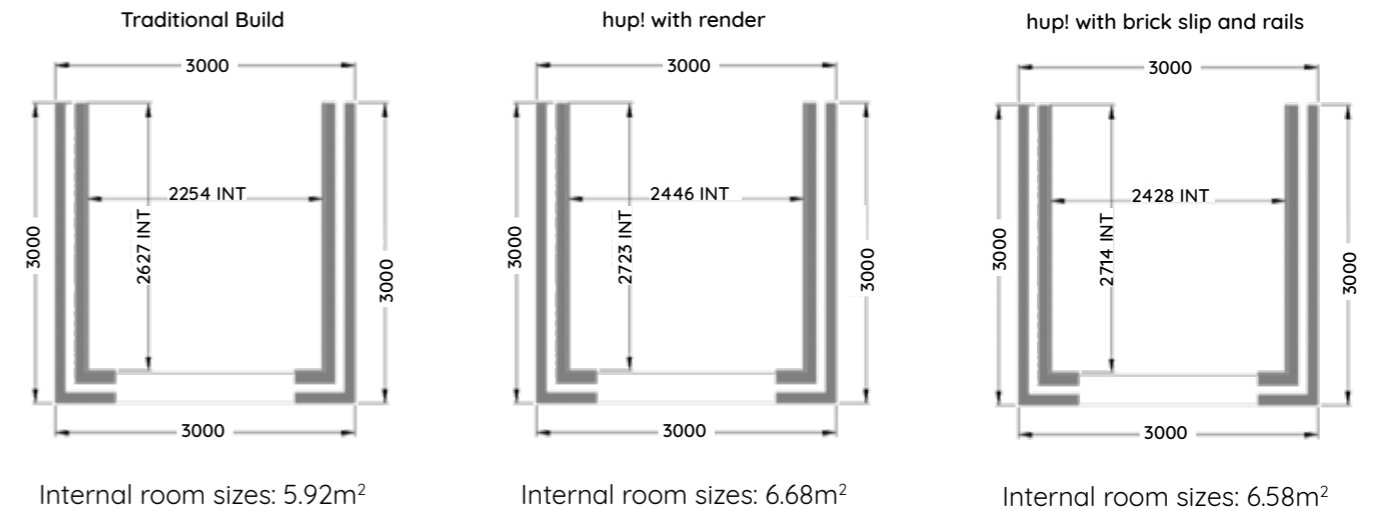

Variable Corners



Variable corners are now available with hup!

Transform old Victorian conservatories in to modern, energy efficient extensions with solid walls and windows wherever homeowners choose. hup!'s lightweight, energy efficient walls are quick, easy, and cost effective to build onto existing bases.

As hup! is so lightweight you can use the old conservatory base and re-build a brand new extension with walls, windows and doors wherever required.

Key specification criteria

- Variable corners are available with wall or window / doors at either side.
- Available in angles from 90° to 170°.
- Suitable for use on 3, 5 and 7 bay Victorians.
- 2 variable corners available: small corner and medium corner.

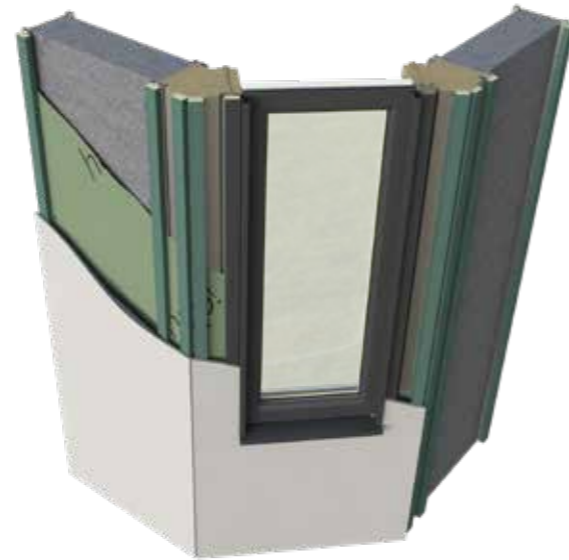

Frame Deduction

Frame deduction with variable corners

When specifying variable corners the size of the hup! corner will be a different size than the existing window frame. The below frame deduction will need to be completed depending on the angle of the hup! variable corner when ordering your window frame.

The table below shows the variable corners going into a window or door frame. Panels next to a variable corner can be used and the sizes range from 100mm up to 600mm, see page 4 for medium corner details showing the corner and panel.

Small Corner (no panel)

External Corner		Internal Corner	
Angle (°)	A (mm)	Angle (°)	B (mm)
95	259	265	75
100	244	260	75
105	231	255	75
110	218	250	75
115	206	245	75
120	195	240	75
125	184	235	75
130	174	230	75
135	164	225	75
140	154	220	75
145	145	215	75
150	136	210	75
155	127	205	75
160	119	200	75
165	110	195	75
170	102	190	75

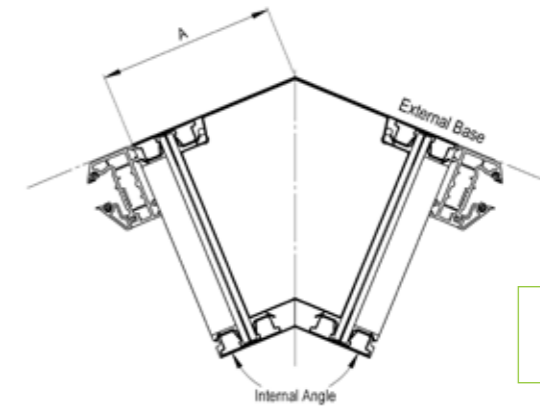

External Corner

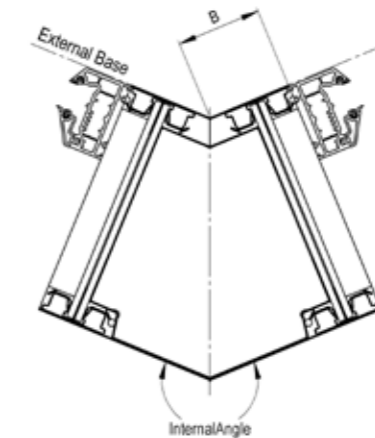

Internal Corner

Frame Deduction

Medium Corner (with panel)

Panels can be inserted next to a variable corner, the size of the panel can range from 100mm up to 600mm.

The table below shows the sizes for a 100mm panel. To work out the frame deduction for other panels sizes, please see details below.

External Corner		Internal Corner	
Angle (°)	A (mm)	Angle (°)	B (mm)
95	359	265	175
100	344	260	175
105	331	255	175
110	318	250	175
115	306	245	175
120	295	240	175
125	284	235	175
130	274	230	175
135	264	225	175
140	254	220	175
145	245	215	175
150	236	210	175
155	227	205	175
160	219	200	175
165	210	195	175
170	202	190	175

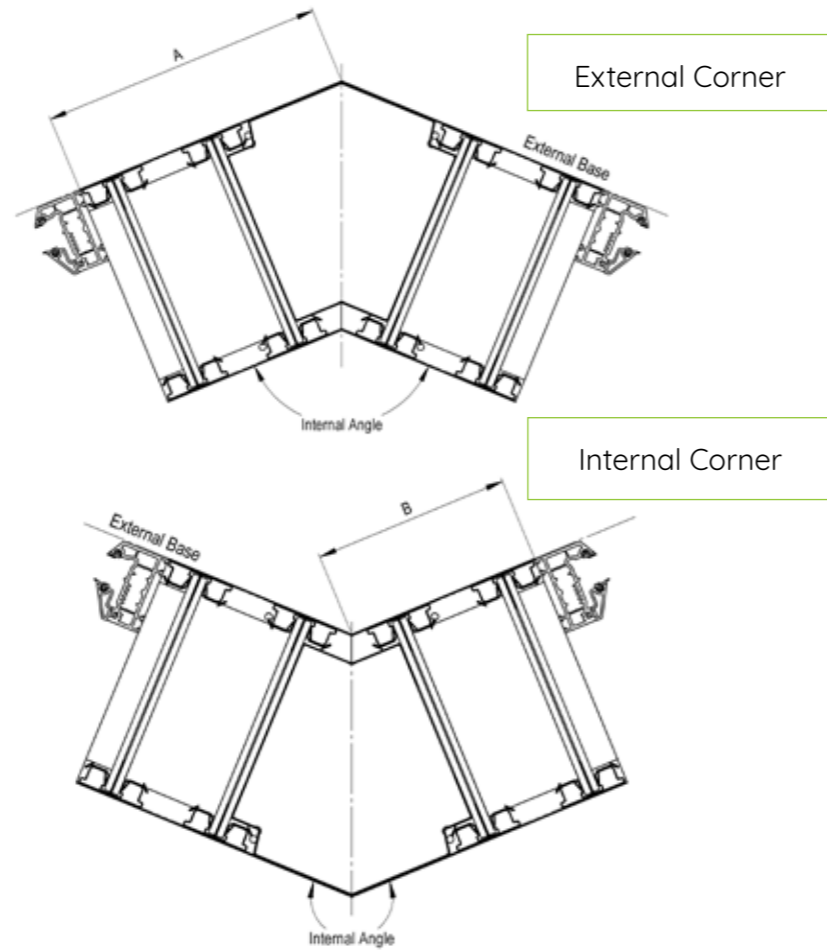

Example for a 500mm panels:

Example: If a 500mm panel is specified, add 400mm (500mm-100mm) to the sizes shown in Internal Corner A (mm) and External Corner B (mm) of the below table.2

Internal Corner		External Corner	
Angle (°)	A (mm)	Angle (°)	B (mm)
95	759	265	575

Design Concepts

See below some design concepts of how you can convert an old victorian conservatory into a hup! extension. These have been shown with a hybrid roof as the roof type but a glass roof or tiled roof can be used.



A solid wall at front finished off in slatted cladding*.



A window within the solid wall finished in render.



A full height window at front finished in render.



A window within the solid wall finished in render with slatted claddings on the wall next to the doors.

*Slatted cladding suppliers are: Ecoscape, Cladco, Neotimber.

Wall Finishes

The hup! system is designed to be used with most wall finishes.

If you are choosing to render the walls or require a fire rated board underneath your wall finish, the hup! calcium silicate board can be provided as part of the system. This is pre-cut to size for fast assembly and is A1 fire rated.

Cement boards or Timber boards can be used too. To install horizontally, vertical battens must be fixed to the steel clips. These battens can be provided pre-cut to size for fast assembly. To install boards vertically, counter battening is required to ensure sufficient continuous ventilation. Counter battens are not supplied.

These are applied to the hup! brick slip rails system, which is pre-cut in panels and rapid to install. No render board is required, speeding up installation significantly.



Rendered Wall Finish



Brick Slips Finish



Horizontal Cement Boards



Vertical Cement Boards



Horizontal Timber Boards



Vertical Timber Boards

What's Supplied?

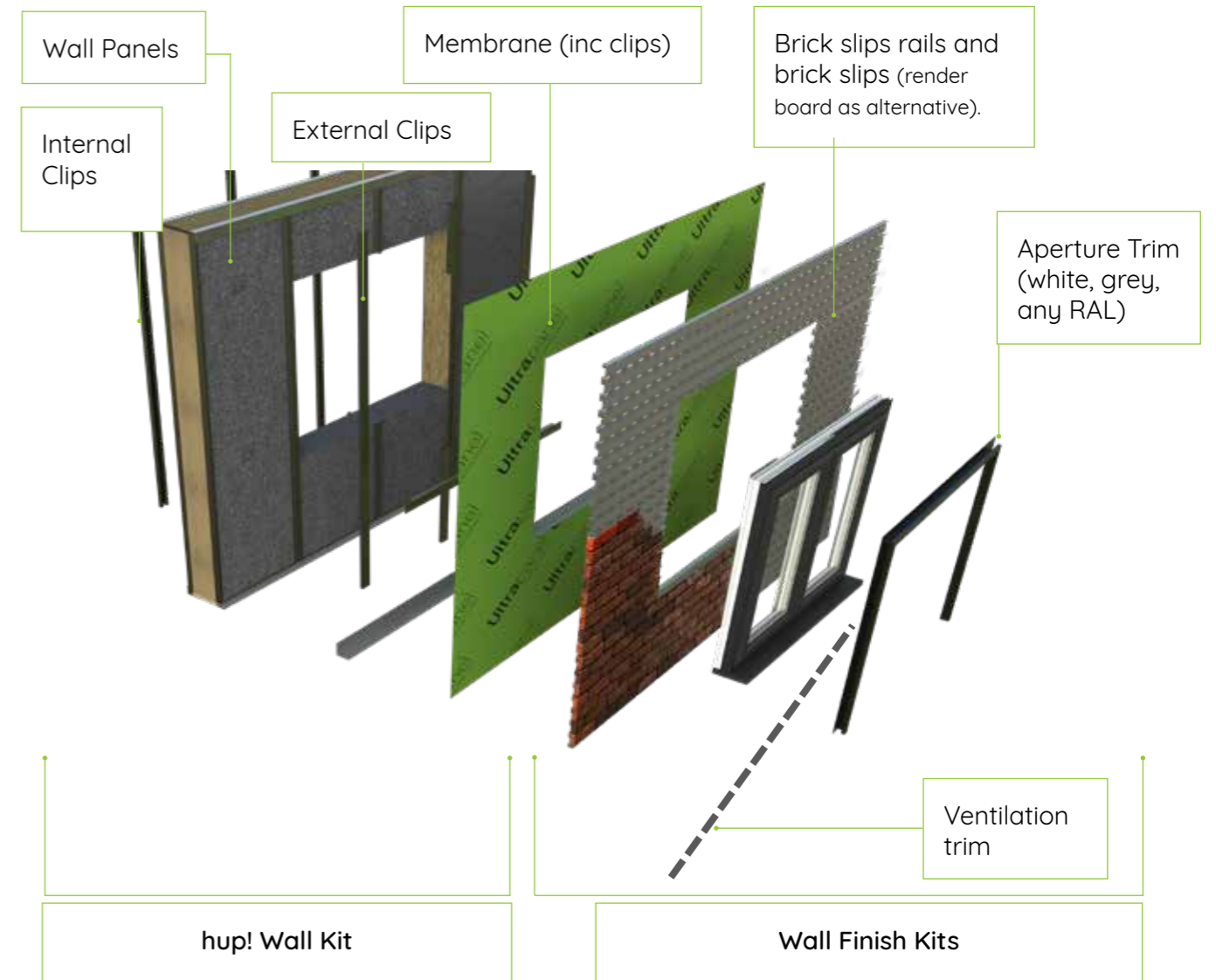

The hup! wall kit consists of everything you need to get your hup! building watertight including Ultrapanel, Ultrapanel clips, wall and base trays, membrane and clips to fix the membrane to the Ultrapanel clips.

It's up to you to decide how you want to finish your wall and we can provide you with all of the elements or, if you want to provide your own wall finishes, we can provide other elements to help you finish your wall as required. Choose from one of the wall kits in the table below which shows you what is included in each kit. Plasterboard is not supplied, we recommend 15mm plasterboard (the roof for Ultrarroof and Livinroof is 12.5mm foiled backed).

Wall Finish Kit	What's included?						
	Battens (cut to size)	Batten Fixings (Required quantity)	Ventilation Trim	Aperture Trim (cut to size)	Render Board (cut to size)	Brick Slip Rail System (cut to size)	Brick Slips
Ventilation Trim			☑				
Aperture Trim				☑			
Battens	☑	☑	☑				
Render Board	☑	☑	☑	Optional	☑		
Brick Slip Rails			☑	Optional		☑	Optional

Wall Finish Kits

Ventilation Trim

To comply with Building Regulations, hup! has a drained and ventilated air gap behind the external calcium silicate board. The system allows for 10mm continuous ventilation.

To prevent vermin or insect ingress and other debris, the wall finish is supplied with a ventilation trim which has 3mm slots incorporated into the profile along its length. This profile runs around the perimeter of the build at the top and bottom of the walling.

The ventilation trim can be ordered separately if using your own wall finishes or it is supplied with the batten, render board. Enough 2.5m lengths are supplied to run along both the top and the bottom of the hup! build.

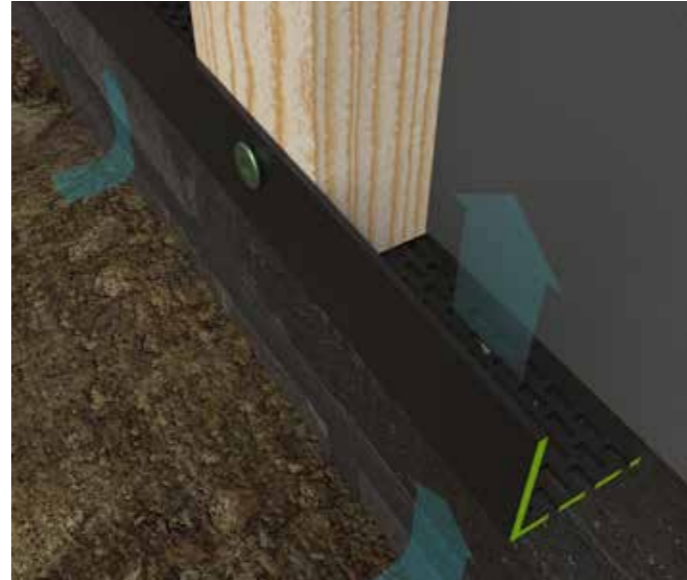

Aperture Trim

The aperture trim accommodates wall finishes up to 25mm which is enough for most wall finishes. If brick slips are used with the aperture trim, the edge of the brick will be visible.

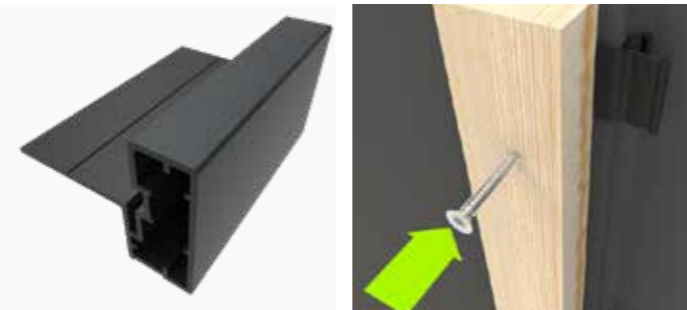

Battens and Batten Fixings

The battens supplied are 25 x 50mm and fit to the Ultrapanel clips with a specialist self drilling winged screw designed to penetrate and fix securely to the timber and the steel clips.

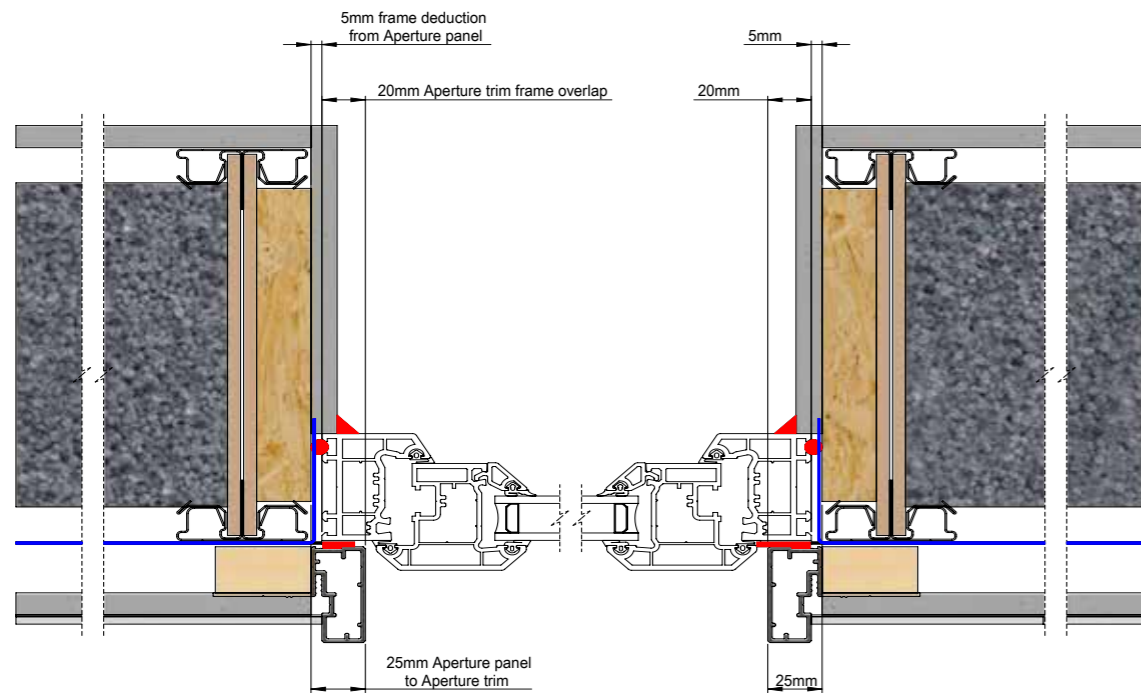

Small frames may require 20mm add ons to avoid opening sashes fouling on the aperture trim, or for aesthetic reasons

Wall Finishes – Render Board

Calcium Silicate Board

Calcium silicate board is manufactured from a mixture of Portland cement, fine silica, special cellulose fibres and selected fillers to impart durability, toughness, fire and moisture resistance.

Calcium silicate panels will not degrade with time and within normal applications. Calcium silicate board will not rot or support fungal growth and is unaffected by sunlight or steam.

Calcium silicate sheet is specially designed for applications which require impact resistance, fireproof (A1 Class), waterproof, sound absorption and heat isolation. These products are suitable in a high humidity environment.

The calcium silicate boards are 12mm in thickness and are pre cut to suit the walling layout of the hup! extension. Each board is marked with its location which coordinates with the provided location plan.

The boards are screwed directly to the timber battens using the provided square drive self drilling screws.

Calcium silicate board fixed to timber batten

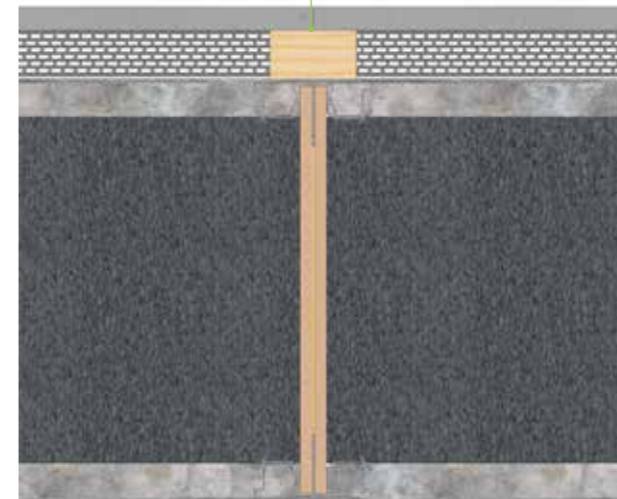

Brick slips rail solution

The hup! brick slip rail solution is available to make the installation of brick slips easier and quicker. With brick slips available in a much larger range of colours and brick matching services available, this product enables hup! installers to offer a genuine brick finish and a closer match to the house.

The rails are supplied as pre-cut, easy to handle panels ensuring the installation is twice as fast as gluing brick slips to a board.

47 shades of brick slips and two shade of mortar are supplied by Ultraframe. For different shades or colour matches, customers can source their own brick slips. The rails are suitable for 20mm or 14/15mm brick slips, but different rail systems are needed for 20mm vs 14/15mm. The depth of the bricks must be specified at order stage to ensure that the correct rail is supplied.



This solution has been fully fire tested and is suitable for boundary walls.

hup! walls with brick slips rails

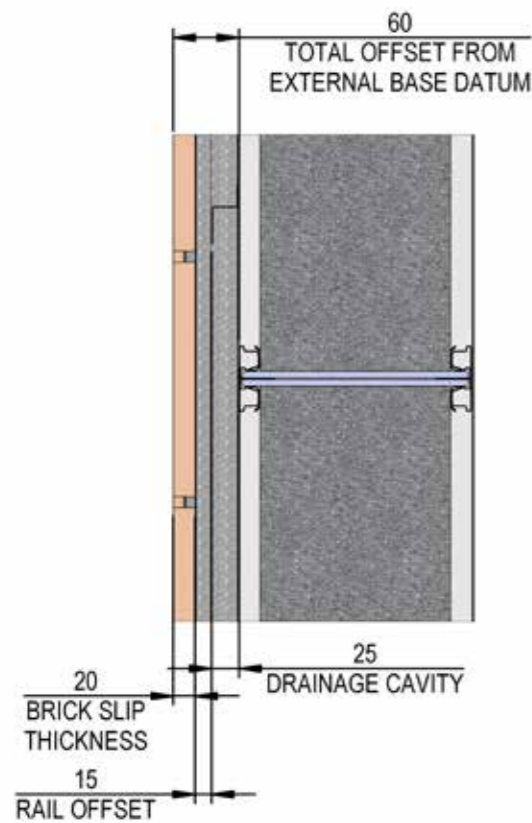

The brick slip rail system thickness is 60mm. Please consider this size when measuring the base for the overhang.

Brick slips rail solution

Technical Details

- Only suitable for metric standard 65mm brick slips, thickness c20mm.
- A minimum 180mm cill is recommended.
- When installing brick slip system, please be aware that the roof lifts up by 10mm. Frame sizes may need to be checked or packed out.
- Wall height must be a multiple of 75mm (the height of a brick course) +10mm.
- Available on all wall corner angles (internal and external). However please note only 90 degree corner slips are commonly available, please check with your brick slip supplier for non-standard angles.
- If using the brick slips rails with a hup! Flat Roof, the extended soffit or 4 tier cornice must be specified.

Brick Slip Rail - Vertical Set out

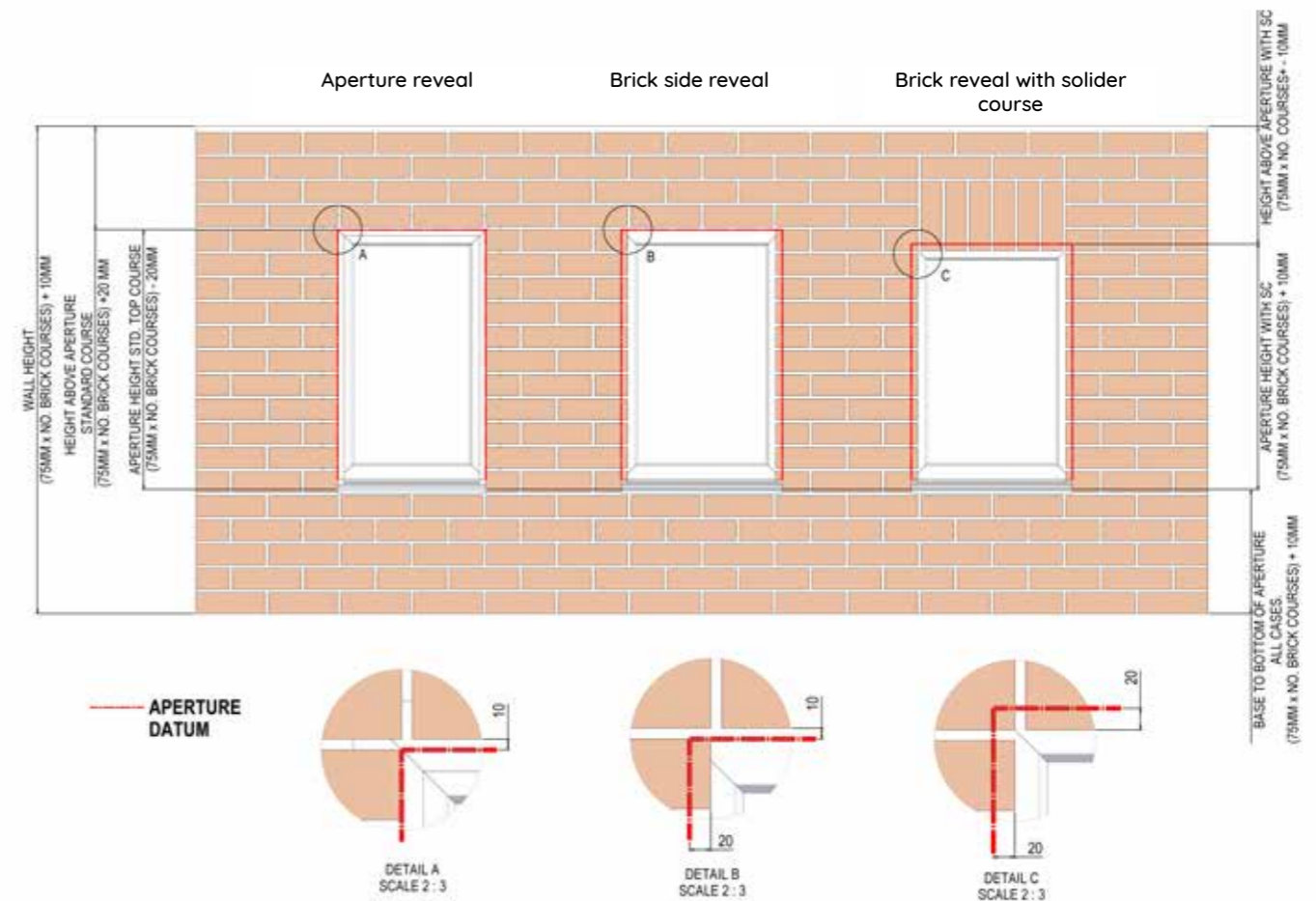

Brick Slip Aperture Reveal Options

Option 1: Aperture Trim Reveal

- Brick course runs up to aperture datum
- Standard Bricks (no brick reveals) used all round
- Aperture trims overlap onto frames by 20mm
- Frame extensions recommended

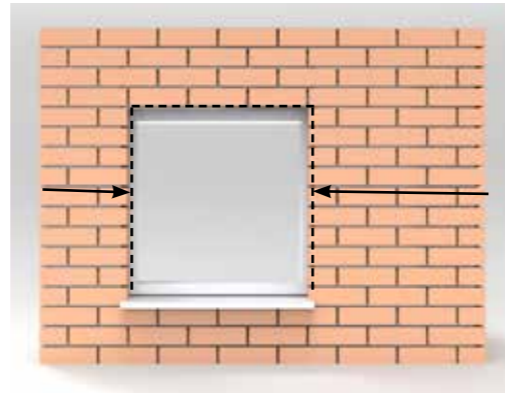
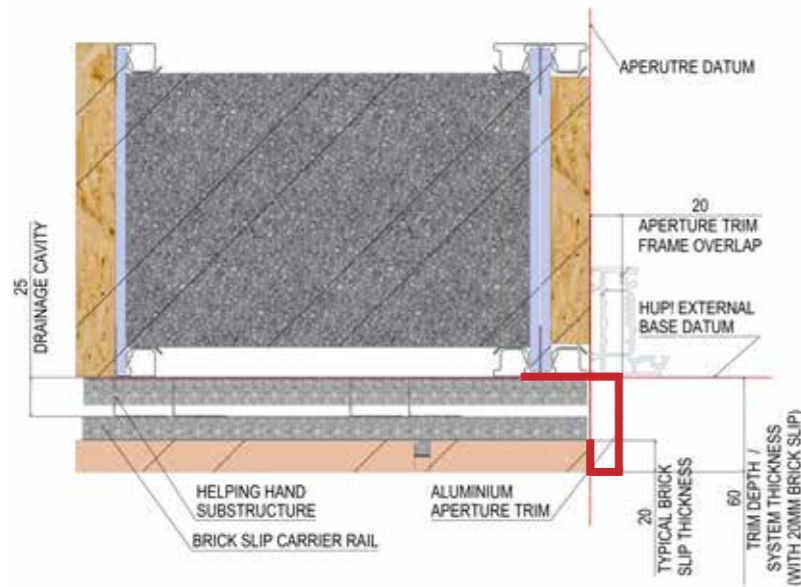

Option 2: Brick side reveal

- Brick course runs beyond aperture datums onto frame by 20mm in horizontal direction
- Corner bricks used on sides of apertures, cut to size at site to run into frame
- Standard course over apertures (no reveal slips)
- Frame extensions on sides recommended
- The “starter rail” over the aperture gives the appearance of a steel lintel, or this can be covered by c30mm uPVC trim (not provided) to match with the frame.

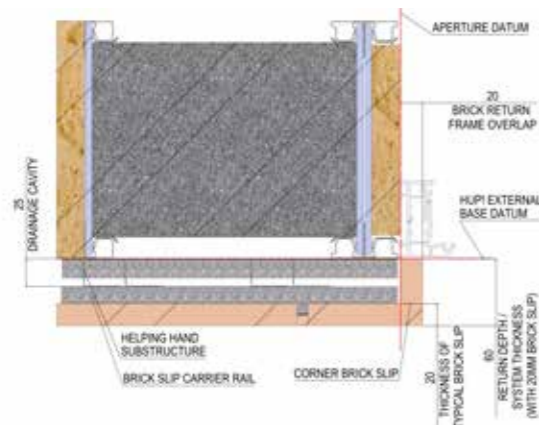

Brick Slip Aperture Reveal Options

Option 3: Brick reveal with slider course

- Brick course runs beyond aperture datum onto frame by 20mm
- Corner Bricks used all round, cut to size at site to run into frame
- No aperture trims
- Frame extensions recommended
- A specialist slider course rail with vertical slots for the brick is supplied for the top of the aperture.

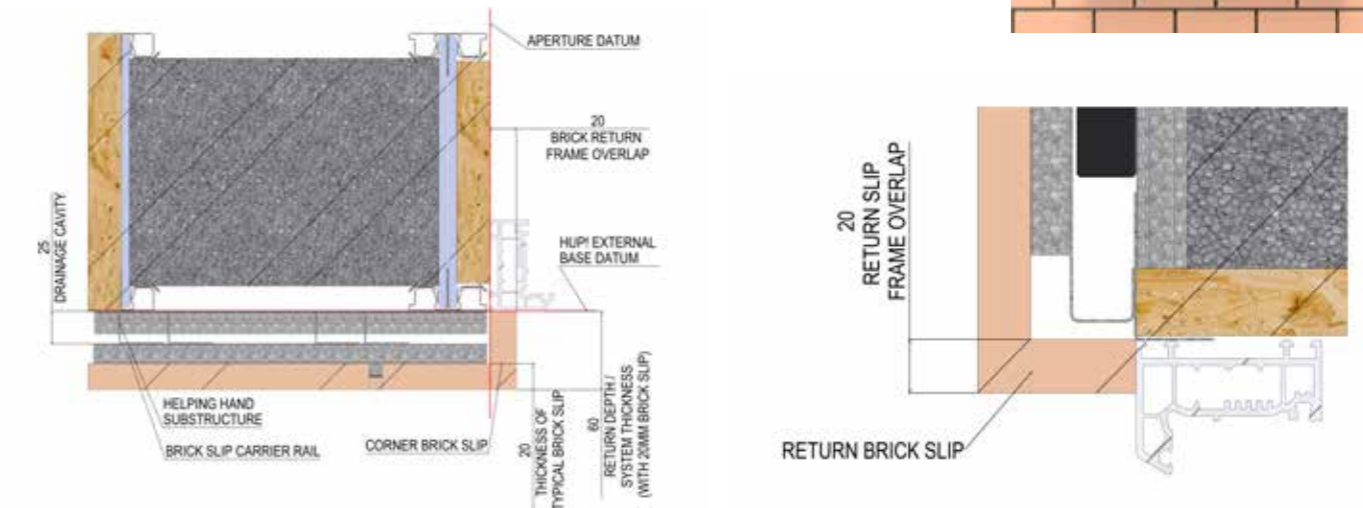

Wall Finishes - Brick slips

The hup! brick slips are available in a range of brick colour and mortar colour combinations to suit the project.

The individual bricks slips are the typically UK house brick (size of 215 mm x 65mm) with corner bricks and half bricks available, and are compatible with the hup! brick rails. Two types of rails can be supplied: one for 20mm brick slips or one for 14/15mm brick slips. If you are sourcing your own brick slips, you must specify the depth of brick to ensure the correct rail is supplied.



Brick Slip Range

Brick slips are now available to order directly with your hup! system. Alongside ordering your hup! walls and brick slip rails system, you can now include brick slips as part of the same, streamlined order, making the process simpler and more efficient.

The mortar provided is a lime-based mortar which we recommend for use with the rails. The shades of mortar available with our brick slips, are White, Natural Grey shades and Sandstone. The rail system is not suitable for use with sand and cement mortar.

The standard brick slip rail system from hup! is designed to accommodate 20mm brick slips. If you choose 14/15mm brick slips you will be supplied with a different rail system, designed for the slimmer bricks.

Ultraframe do not provide a colour matching service and should you wish to source your own brick slips and these are slimmer than 20mm, you should inform your installer/Ultraframe, to ensure the correct rail system is specified.

To order any samples, please email sales@hupbrickslips.co.uk.

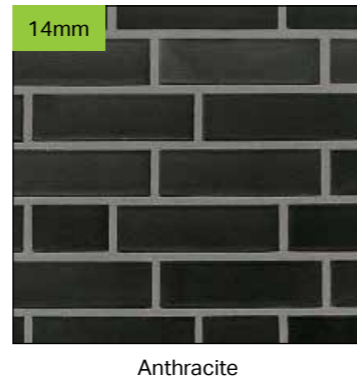

Faro Grey

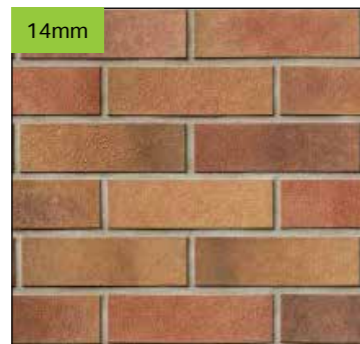

Toulouse Red



Toulouse Beige

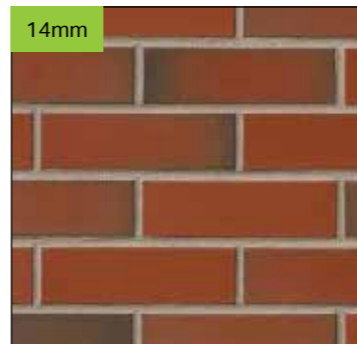

Old Colliery



Red Origin Smooth



Red Origin Sanded



Red Ember Sanded



Red Hearth Sanded



Red Midnight Smooth



Brown Castana Sanded



Yellow Citrine Smooth



Yellow Citrine Sanded

Brick Slip Range



Purple Amethyst Smooth



Light Greyscale Smooth



Black Onyx Smooth



White Lunar Sanded



Rustington Antique



Traditional Red Blend



Audley Antique



Euphoria



St Andrews



Farmhouse Antique



Shelford Cream

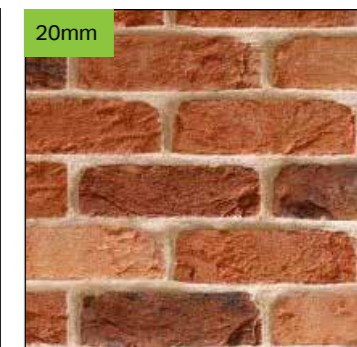

Old Coach House

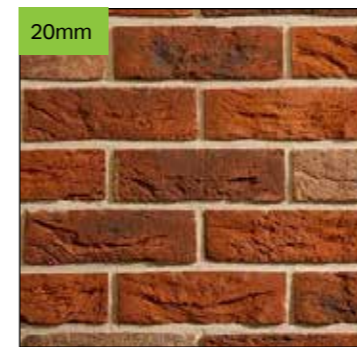

Keswick Blend



Reclaimed Restoration



Welbourne Antique



New York Blend

Brick Slip Range

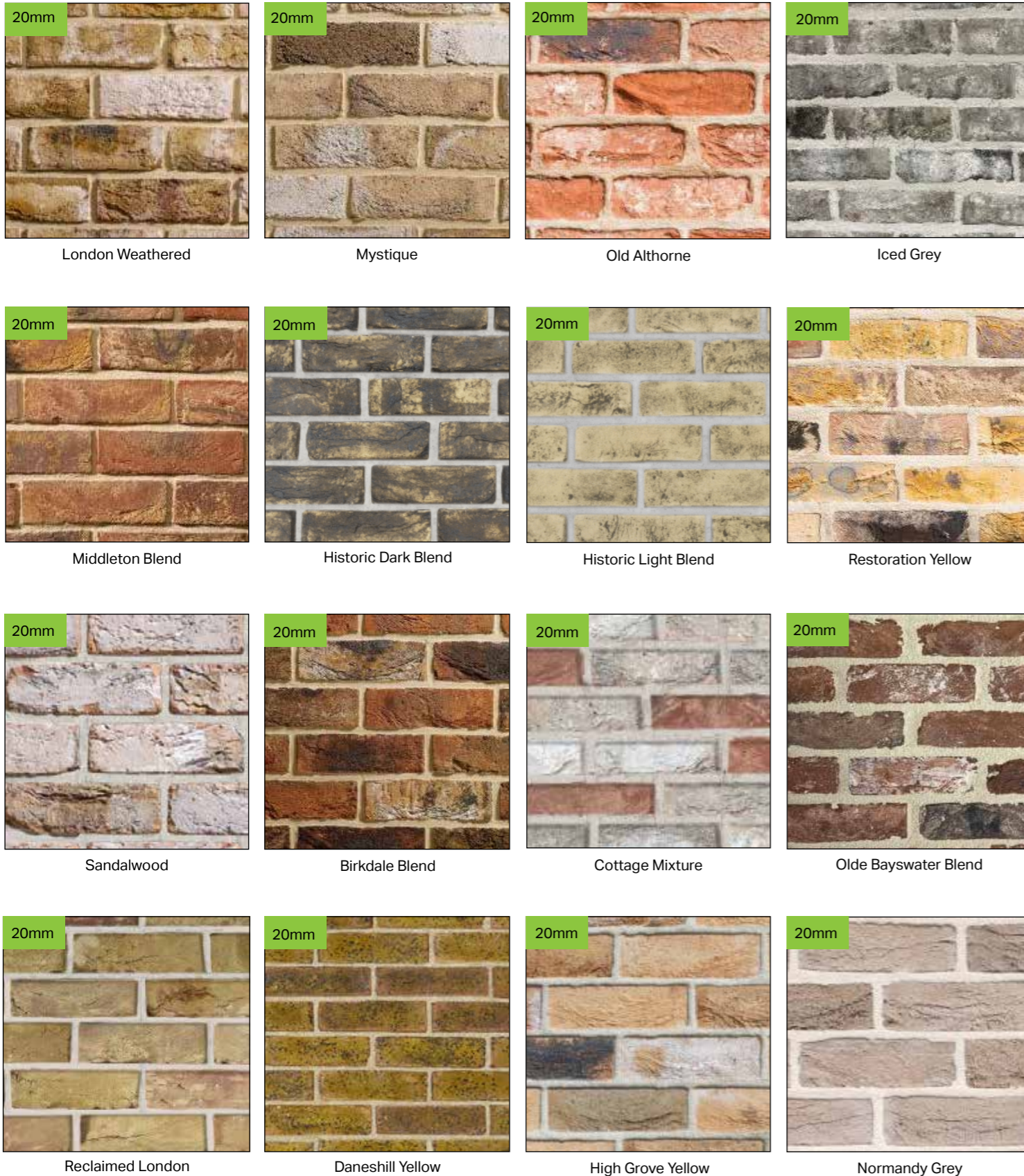

Render Options

Most renders are appropriate to use with hup! however we recommend a thin coat silicone render, such as Ecorend and K Rend.

If you are choosing to render the walls or require a fire rated board underneath your wall finish, the hup! calcium silicate board can be provided as part of the system. This is pre-cut to size for fast assembly and is A1 fire rated.

Remember that cement render is unlikely to work with the hup! aperture trim around apertures as the render will be thicker than the trim. If you use a cement render you will need to provide your own render drip trim suitable for the type of render you require.



External Cladding

Most external cladding systems can be used with hup! e.g. fibre cement claddings, timber claddings, cedar style claddings, or composites. You can mix and match different colours, effects and finishes to achieve the customers desired look.

Depending on the external cladding the sequence of the battens and calcium silicate board may change as referred to in the installation guide. For cement boards you will need to consider the counter battening for vertical installation to maintain ventilation. If used horizontally they can be installed directly onto the battens, however if used vertically you will need to counter batten on top of the existing battens. Do not horizontal batten straight onto Ultrapanel clips as this will prevent ventilation behind the cement boards.

Regardless of fire classification the hup! calcium silicate board will need to be used within 1 metre of a boundary or unprotected area space to ensure sufficient external fire protection. Claddings with a fire rating of less than Class B, S3, D2 should never be used on a boundary even with calcium silicate board. Please refer to Building Control Part B, for unprotected area calculations when further away than 1 metre.



Steel Façade

The hup! steel façade is a lightweight, quick and easy wall finish for boundary walls where access is limited and there are no apertures. Available in grey, the steel façade can be finished with a trim on the corner of the boundary wall, or can finish short if you wish to carry on the wall finish from the front around the corner. hup! steel façade is supplied in 3m lengths which are to be cut down on site. The calcium silicate board should be fixed directly to the clips and then the fixed to the outside of the board before the steel façade is then fitted. Using the boundary wall hinge system, this lightweight boundary wall is easily manoeuvred into place.

Fire rating for hup! steel façade: The façade is fitted to the hup! wall with calcium silicate board which has a 30-minute fire rating. The steel façade is A1 rated in accordance with EN13501-1.

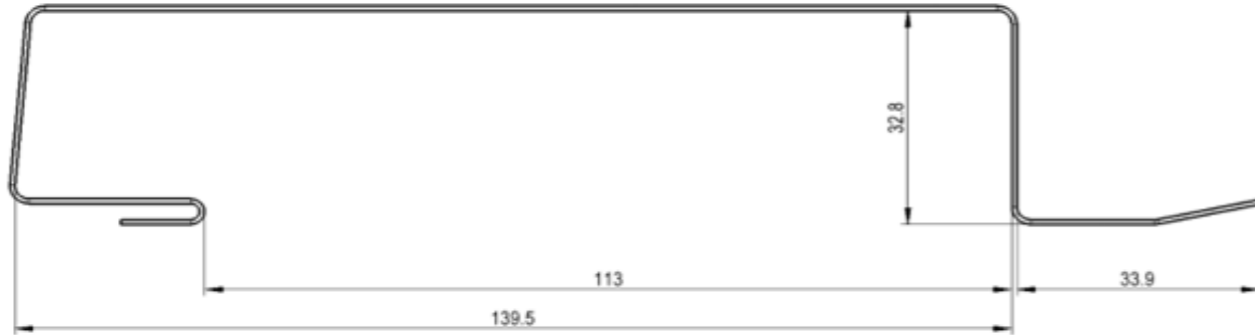

Profile Dimensions:
The main profile (M-17103) detailed below needs to be supported internally when a cut is required. This helps the profile maintain its shape when cutting and provides the best result.



Standard 2100mm boundary wall

Raked boundary wall - standard 2100mm

M-17109 - Profile 14	2100
M-17103 - Profile 13	1940
M-17103 - Profile 12	1790
M-17103 - Profile 11	1640
M-17103 - Profile 10	1490
M-17103 - Profile 9	1340
M-17103 - Profile 8	1190
M-17103 - Profile 7	1040
M-17103 - Profile 6	890
M-17103 - Profile 5	740
M-17103 - Profile 4	590
M-17103 - Profile 3	440
M-17103 - Profile 2	290
M-17103 - Profile 1	140

Specification Guide | 01200 414607

Steel Façade

Flat Roof classic with steel facade

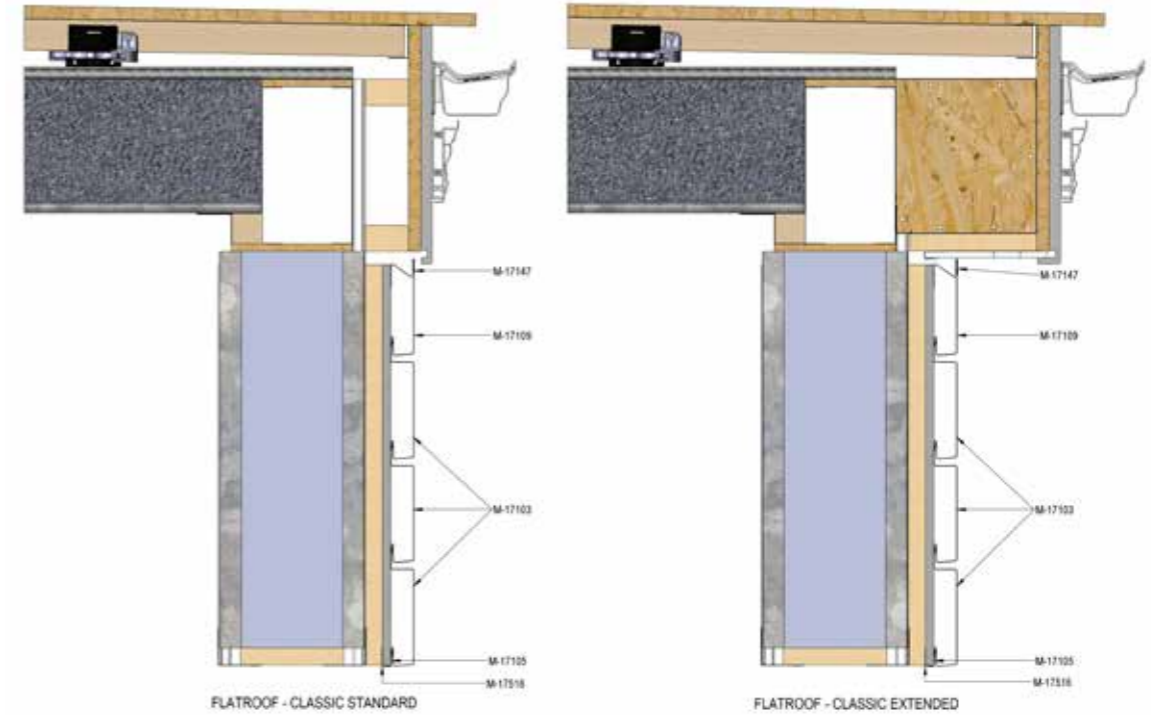

4 tier and Ultrarroof with steel facade

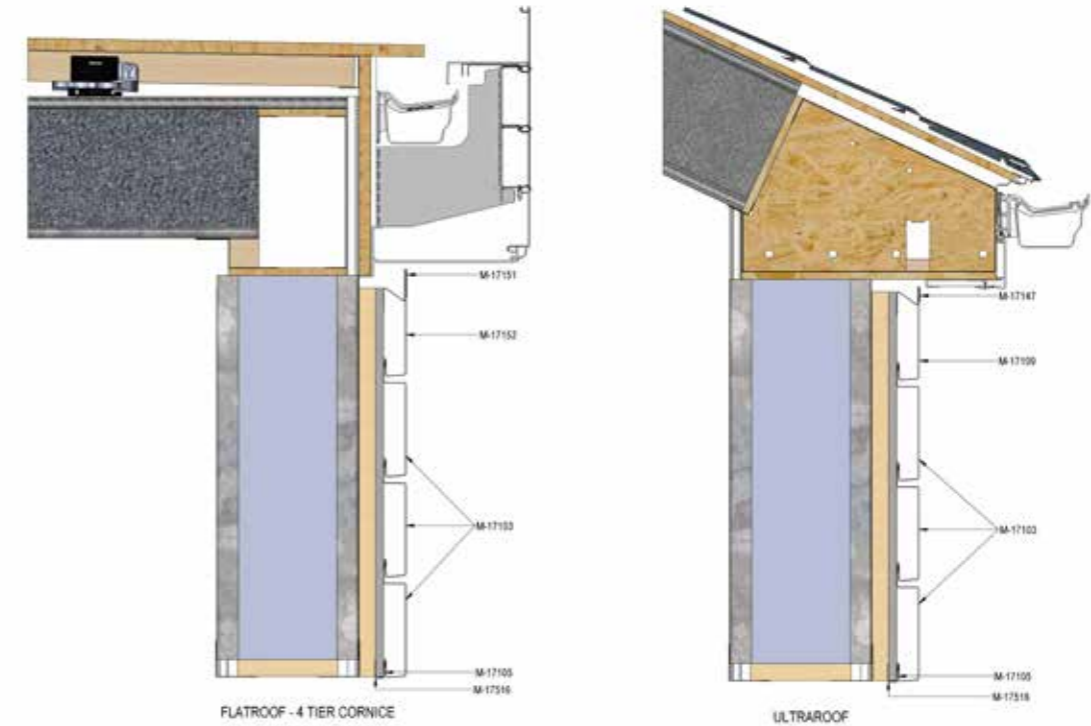

Flat Roof 2 tier with steel facade

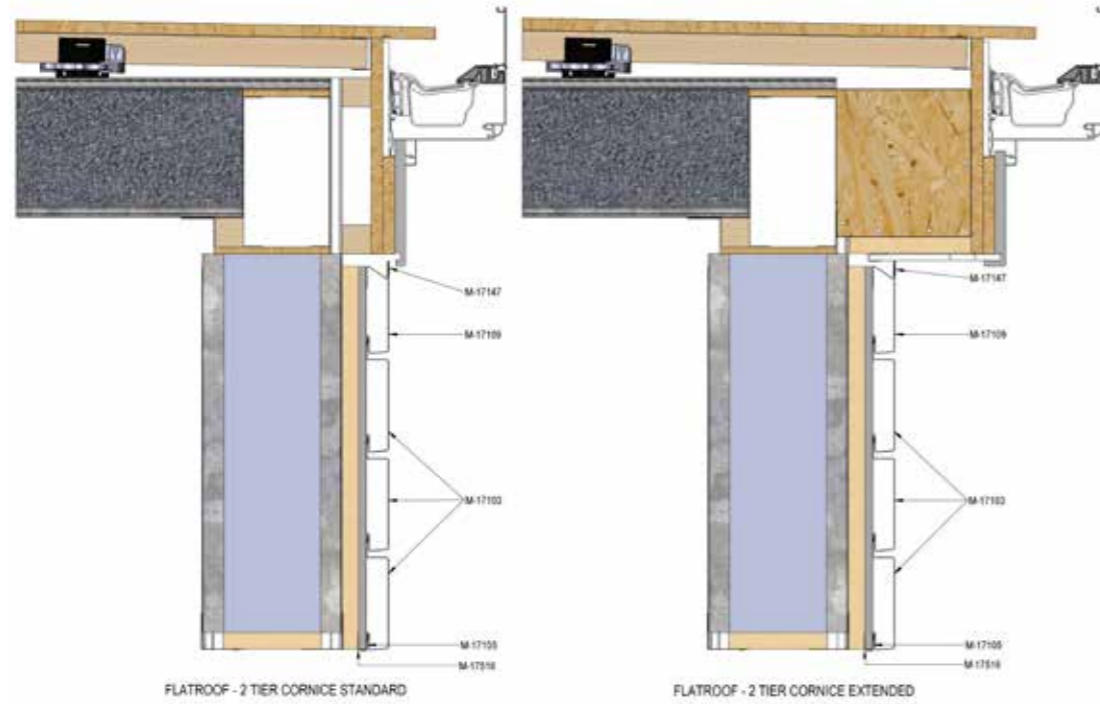

Classic with steel facade

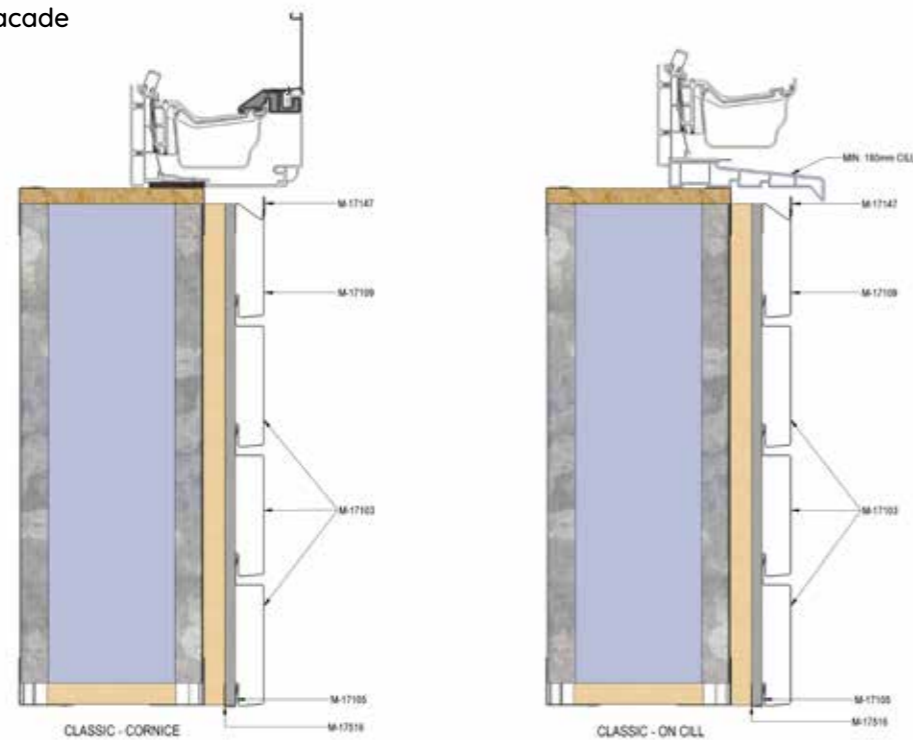

Wall Finish Design Considerations

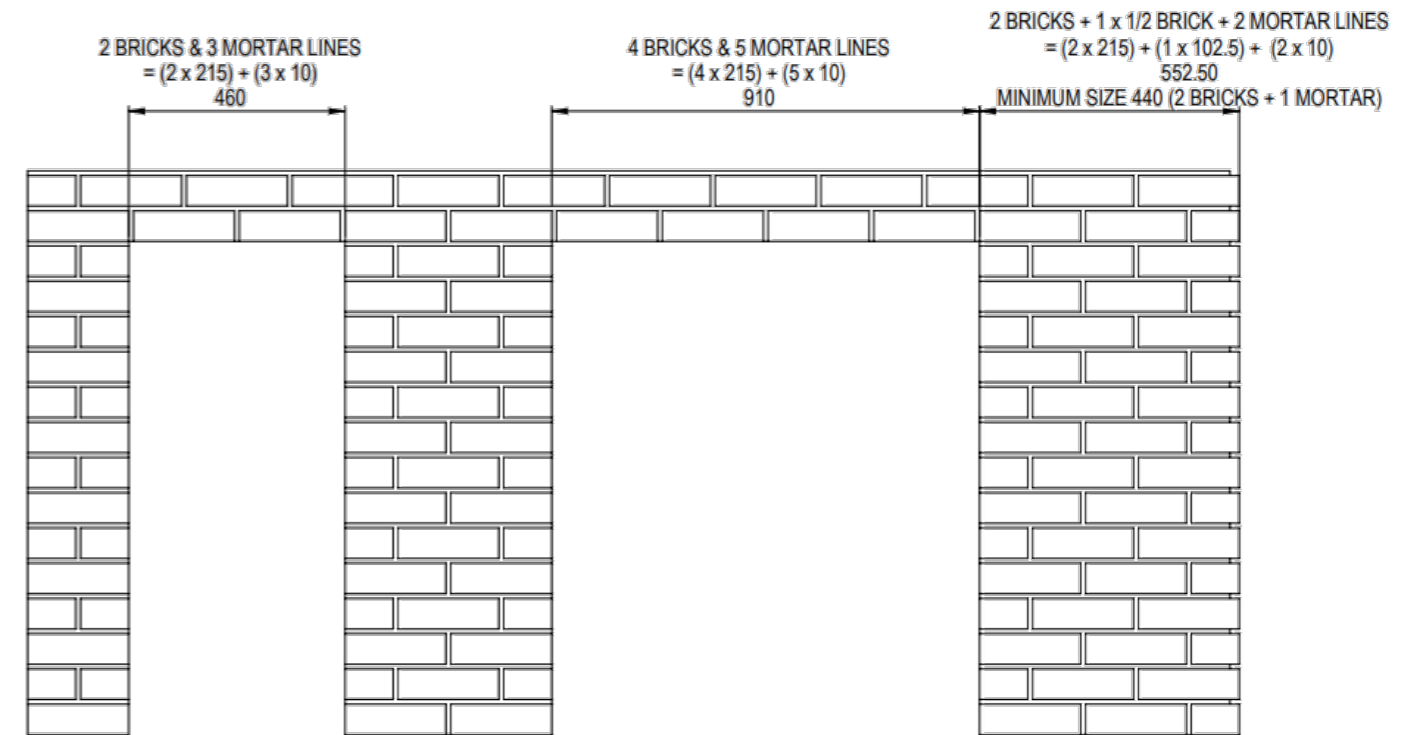

Important Design Considerations

The bricks sizes are to standard UK stock brick sizes and therefore to ensure the best and most convincing aesthetic, openings should take the brick size into consideration. We have the option for the sizes to be checked within the software and recommendations made to move openings to achieve the best aesthetic.

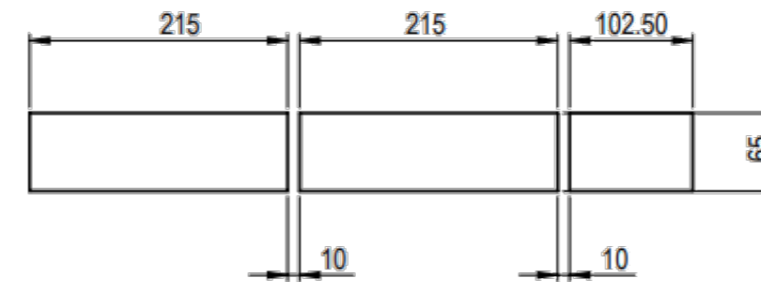

STANDARD UK BRICK SIZES
LAYOUT BASED ON BRICK & HALF BRICK

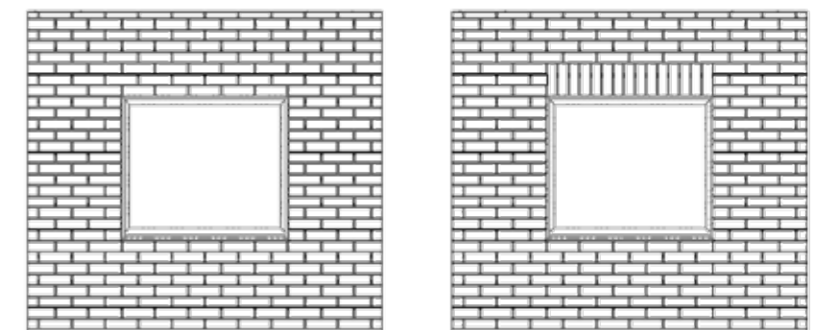

hup! on existing dwarf walls

Whether you are replacing a window with a small hup! wall or removing all the frames and creating a home extension, this option offers more transformation options to conservatory owners.

Using existing walls saves on demolition mess, time on site, skips costs and allows customers to keep existing flooring saving homeowners £000's on their quote.

It is the responsibility of the installing company to assess the existing wall for stability and foundations by way of trial hole to determine if both are adequate to build upon. hup! only suitable on use on 250mm and 300mm brick and block cavity walls with no signs of movement.

Options

hup! can be placed 'on cill' for jobs where the dwarf wall may be out of square and the 'full clad' option allows for the calcium silicate board to run the full height of the wall for a more premium look. You can use hup! on most sizes of dwarf wall, 250mm and 300mm walls.

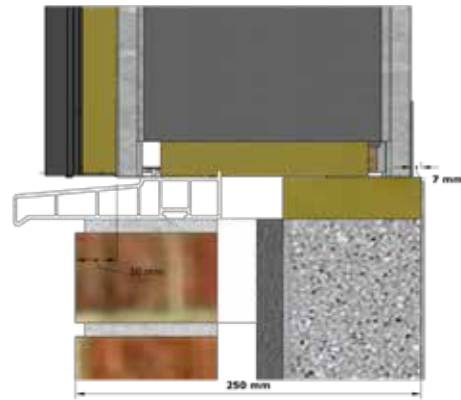

hup! on 250mm existing wall - on cill

On Cill option

The external surface of the hup! wall steel clip is aligned 30mm back from the external brick, the battens carrying the claddings then run down the clips and finish at the end of the hup! wall. This option is preferable where the existing wall is out of square and there may be run-out between the hup! wall and the existing wall.

If using this option, specify internal frame sizes for your hup! order.

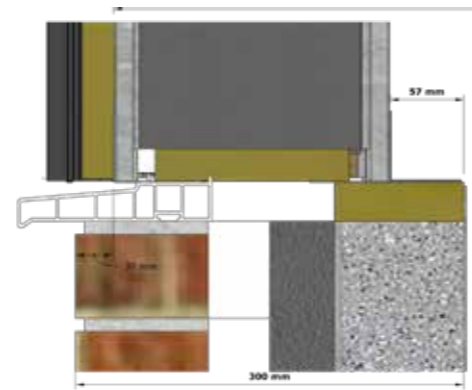

hup! on 300mm existing wall - on cill

On Cill option overview

- Use internal frame dimensions to order on cill option.
- The on cill option is not suitable for use on a boundary because the cill is classed as a unprotected area and the new wall will not meet fire safety regulations.
- The existing cill can be left in place. To specify the correct size measure the existing internal frame size and specify the internal frame size for the hup!
- Using the cill as the datum will ensure there is an even offset from the cill to the wall finish. This option is good where the walls are not square, the cill will hide any discrepancy between the hup! and dwarf wall.
- This option is suited to situations where the wall height is to be increase only on one of the elevations e.g. boundary wall only.
- The wall follows the same rules as hup! therefore, the wall cannot finish on the existing window corner. The wall must stop short of the corner with a window frame joining the hup! wall to the window corner. Alternatively, the hup wall returns around the corner with the standard 275mm return.
- The standard aperture trims can be used.
- The internal face of the hup! wall is set in relative to the internal block on the dwarf wall. Offset is 7mm on 250mm wall and 57mm on a 300mm wall.

hup! on existing dwarf walls

Full Clad Option overview

- Use the standard hup! datum, this positions the outside of the hup! wall in line with external brick.
- If you are using Flat roof or Ultrarroof, the windows can be kept in the usual position if needed. i.e. the inside face aligned to the inside face of the external brick. This will require a deeper trim than the standard hup! aperture trim which is not supplied.
- When surveying if its apparent the width or projection is varying, use the largest dimension to specify the hup! This will ensure the external clips are in line with or in front of the external brick and the battens can run right through.
- If the hup! Calcium silicate board is being used, the height of the existing dwarf wall needs to be provided.
- The internal face of the hup! wall is set in relative to the internal block on the dwarf wall. Offset is 37mm on 250mm wall and 87mm on a 300mm wall.
- When using a Glass or Hybrid Roof the window position must be moved forward.

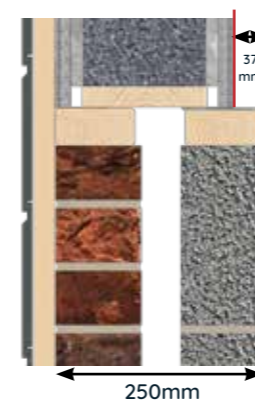

hup! on 250mm existing wall - full clad

Full Clad Option

The external surface of the hup! wall steel clip is aligned with the external brick, the battens carrying the claddings then run down the clips and over the surface of the bricks such that the external finish appears as one.

If using this option use external base size for your datum when you order.

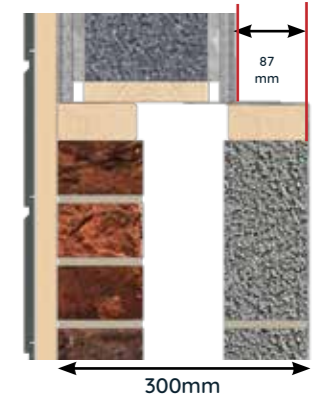

hup! on 300mm existing wall - full clad

Both options for hup! on existing dwarf walls

Specification

Due to wall thickness the wall should not finish directly into a corner post, either-

1. Finish the wall short of the corner and have a window between the wall and corner post

Finish the wall with a hup! wall corner (minimum 275mm return) and start the window on the adjacent elevation in from the corner. This will almost always require a new window frame.

Internal Finish

The internal finish can be made flush with the existing dwarf wall finish however this will require packing out (materials not provided). An option to consider is making a feature of the offset internal wall eg shelves recessing a TV etc. To structurally fix the wall plate down with the steel straps some plasterboard will need to be removed from the dwarf wall.

Wall plate

The internal leaf needs a treated timber wall plate which is not provided by Ultraframe. This must be at least 95 x 30mm as a minimum and should be bedded on mortar and strapped down the internal face of the wall. When specifying the hup! wall height the dimension will be from the top of the wall plate not the existing wall. Please note that to structurally fix the wall plate down with the steel straps some plasterboard will need to be removed from the dwarf wall.

Fire Performance

A variety of claddings can be used to finish the wall, please note if within 1m of a boundary calcium silicate board must be used, and the spread of flame performance of the finish must be a minimum of B-S3 D2.

hup! on existing dwarf walls

Thermal Upgrade requirements

If Building Regulation approval is required for the renovation the new wall in its entirety needs to meet Building Regulation thermal requirements. This means that the existing dwarf wall together with the new hup! wall combined performance should have a U-value of at least $U = 0.18 \text{ W/m}^2\text{K}$.

It is the responsibility of the installing company to assess the existing wall for stability. This comprises of a trial dig to establish ground conditions and depth of footing. Then to investigate the type of internal blockwork that you securing to is sufficient. Pictures must be taken and submitted to your Building Control as part of your application. You must taken evidential pictures to show you have installed the hup! wall in-conjunction with the installation guide.

250mm existing wall width up to 1000mm tall

Existing cavity insulation	Revised cavity insulation	Internal insulation
25mm PIR		60mm PIR
25mm Rockwool		75mm PIR
Empty	50mm EPS beads	60mm PIR

300mm existing wall width up to 1000mm tall

Existing cavity insulation	Revised cavity insulation	Internal insulation
50mm PIR		50mm PIR
60mm Rockwool		60mm PIR
Empty	100mm EPS beads	40mm PIR
50mm PIR	50mm PIR & 50mm EPS beads	25mm PIR
60mm Rockwool	60mm rockwool & 40mm EPS beads	40mm PIR

Examples of hup! walls on existing dwarf walls:



Before



Replace windows with hup!



New frames and hup! walls on cill.



New frames and hup! walls full clad.

Wiring Details

Cable Management Panels

A cable management panel option is available for running cables around the perimeter of the build. It is supplied on every panel if this option is selected.

- The cable management will appear if selected on applicable panels above 560mm.
- The channel is set at 450mm above the DPC level and allows holes to be drilled between panels through the hardboard and cables fed through.
- The channel is deep enough to cater for socket back boxes.
- If cables need to be run up the wall, or around apertures, the cable must be sheathed in a flexible conduit to avoid contact between the cable and the EPS.
- All electrics must be carried out by a certified and qualified electrician.

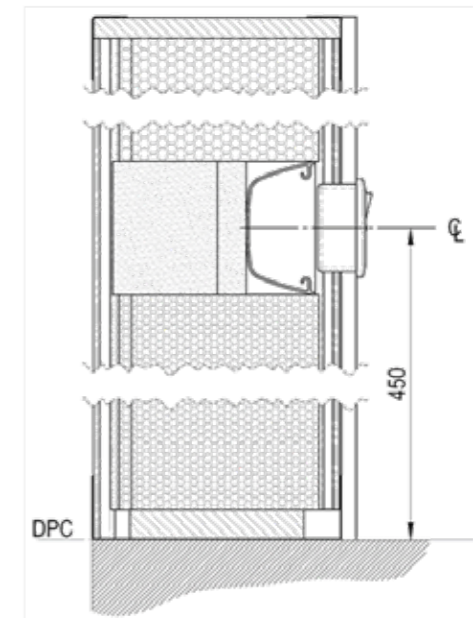

Alternative Methods (for Glass and Hybrid Roofs only)

If a cable management panel is not specified, the wiring can be run around the perimeter of the eaves and then dropped vertically to the required position of the socket or switch. When running the cable across or down the face of the EPS, the cable must be run in a flexible conduit.

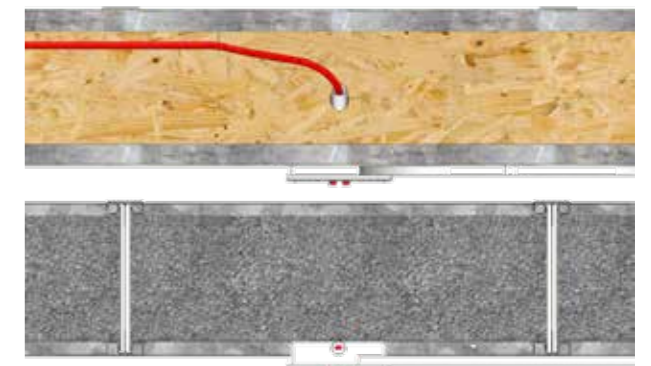
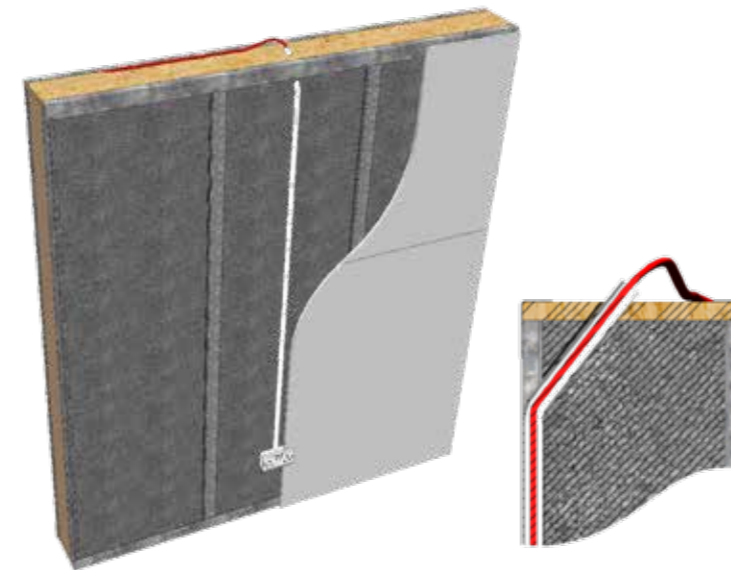

Drill hole through top tray and EPS to thread conduit through.

Wiring Details

Alternative Methods - (Tiled and Flat Roof)

If a cable management panel is not specified, the wiring can be run around the perimeter of the eaves and then dropped vertically to the required position of the socket or switch. When running the cable across or down the face of the EPS, the cable must be run in a flexible conduit.



Option 1

Drill a 20mm diameter hole either side of the clip into the back of the beam. Push in a grommet to protect the cable against the steel edge. Using a rigid wire pull string through the holes to enable feeding cable through.

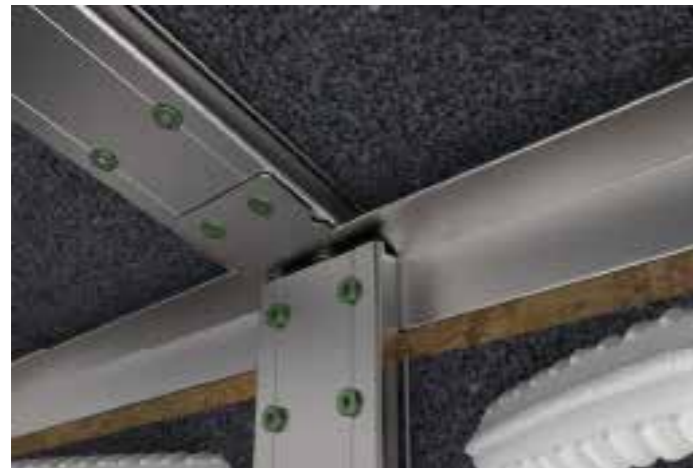

Option 2

Drill an angled 20mm diameter hole (shown in red) either side of the clip into the EPS and break through the hardboard behind the steel clip. Using a rigid wire pull string through the holes to enable feeding cable through. Ensure that cable is in conduit to isolate from the EPS.



Pipework Details

- Pipework should be located in a dedicated service void or behind skirtings and where practical, provide access for pipe bends, stop valves etc. This can be achieved by creating a void behind skirting by using custom 'ripped down' battens to pack the skirting away from the plasterboard, or by using a purpose manufactured rebated skirting.
- Alternatively, pipework can be ran via the cable management panel along with any electrical or network cables, providing that there is a minimum 25mm gap.

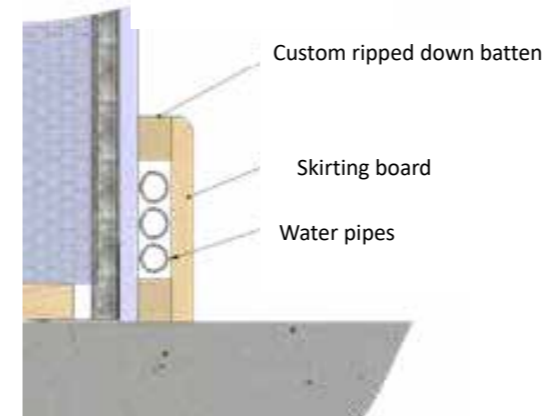

Skirting boards can be purchase with a ready made void for pipes as shown to the right.



Dedicated rebated skirting to accommodate pipework.

Recommended Fixings (not supplied)

Some fixings for the hup! building system are not supplied, however below are some recommended fixings for securing the walls to the base and fixings for hanging heavy objects from interior or exterior walls.

Base Tray Connection Detail

We recommend for speed of installation, self cutting concrete screws (6mm x 85mm minimum) with a minimum pull out of 1KN to fix the base tray to the concrete base. Alternatively, sleeved anchor bolts can be used.



Self Cutting Concrete Screw



Sleeved Anchor Bolt



Wall Plate Connection Detail

We recommend fixing the wall plate to the host wall using a masonry frame fixing screw.

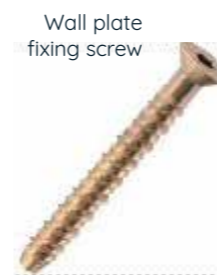

Wall plate fixing screw

Hanging objects from interior walls

Use an appropriate hollow plasterboard wall fixing to accommodate the required weight of the object to be mounted. We recommend expanding fixings which help distribute the load over a larger area.



Steel Hollow Wall Anchor



GRIPIT Plasterboard Fixings (Various weight carrying capacities)

Alternatively the interior walls may be lined in plywood before plaster boarding, or boarded with Fermacell board which can take 50kg per fixing and can be directly plastered for a final finish. We recommend plywood lining or expanding fixings when hanging heavy objects off the walls such as kitchen

Apertures

Apertures can be located at the bottom, the top or anywhere in between and also run full height.

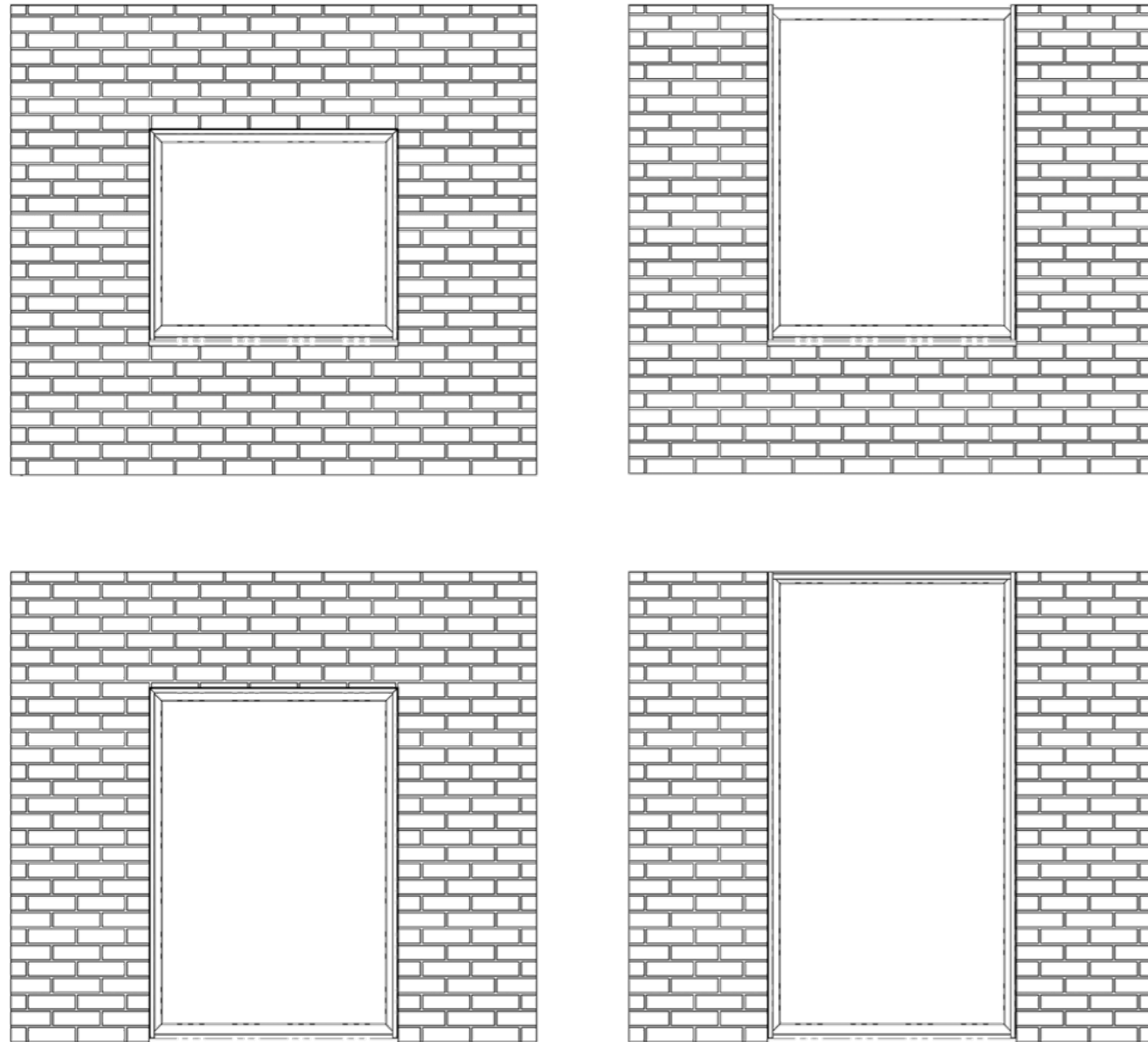

If using the hup! corner, apertures must be a minimum of 275mm from the corner of the base.

If locating an aperture between the top and bottom of the elevation the apertures must be a minimum of 215mm from the underside of the beam and 200mm from the DPC level at the bottom.

All aperture sizes will be confirmed at order stage. These will be 'tight' sizes, so you will need to make the necessary deductions when you order window and door frames.

Support Beams

Support Beams - No Lintels Required

When a soldier course is used across the top of doors a support beam will be built into the wall at no extra cost, which runs across the top of the door between the walls. The maximum door span is as follows. There is no need for additional lintels as a support beam is provided at no extra cost. Please note that when using large door openings lateral stability must be considered. If larger door spans are needed, please consult Ultraframe.

Situation		Wall finish	Roof pitch (°)	Max Span (mm)
Glass Roof		Render or brick slips	15 - 40	4500
Hybrid Roof			15 - 40	4500
Flat Roof	N/A		4500	
Tiled Roof	15 - 40		4000	
Tiled Roof Gable		Render	15 - 25	4500
			26 - 40	3500
		Brick Slips	15 - 25	4000
			26 - 40	3000
Tiled Roof Lean to		Render	12.5 - 15	4500
			16 - 25	4000
			26 - 35	3500
		Brick Slips	36 - 40	3000
			12.5 - 15	4000
			16 - 25	3500
			26 - 40	3000

Gable Reinforcement

When using glass above an opening on a gable end, a gable support beam is used which sits above the doors between the hup! walls. The table below shows the maximum span of the gable support beam in certain situations.

Situation	Image	Wall Finish	Roof pitch (°)	Max Span (mm)
Duo pitch gable with hybrid or glass roof		Brick slips or render (If claddings are heavier than 22mm brick slips, please contact the technical team)	15-40	5400
Lean to with glass or hybrid roof			5 - 17	5400
			18 - 40	5100
Duo pitch gable with tiled roof and glazing			15 - 19	5500
			20 - 25	5200
			26 - 30	5000
			31 - 35	4700
			36 - 40	4500
Lean to with tiled roof and glazing			12.5 - 15	5200
			16 - 20	5000
		21 - 35	4500	
			36 - 40	4000

Key



Ventilation

Any hup! must be ventilated in accordance with Building Regulations with the installation of trickle vents in windows as necessary. If the new hup! room has a kitchen, additional ventilation like an extractor fan should also be installed. Please refer to Building Control Document, Part F Ventilation for further information.

Datums

External Base Datum

The outside of the edge of the Ultrapanel clips and base tray align with the outside of the base brickwork or shuttered concrete edge.

External Cladding Datum

25mm battens are required to accommodate any wall finishes and depending on which wall finish you choose these will over hang the base datum by around 40mm. For example on hup! the base datum is 3mm membrane and clips, 25mm battens, plus 12mm calcium silicate board, plus wall finish thickness.

Other cladding thickness will vary e.g. brick slips and timber cladding. Please provide us with your chosen cladding thickness to enable us to generate the external cladding datum on the reports.

Internal Wall Datum

This sits 215mm inboard of the external base, including plasterboard this is 230mm.

Internal Frame Datum

The external face of the window or door frames lines up with the panel clips on the external base datum. With traditional 70mm frames the internal frame line sits 70mm inboard of the external base datum.

Boundary Wall Situations

It is possible to install hup! walling next to a boundary wall or where access is restricted. You will need to specify which wall is on the boundary so a specific boundary wall kit is provided.

The kit consists of a wall hinge, PVC tray and skids so that the wall can be fully assembled then moved into final position easily.

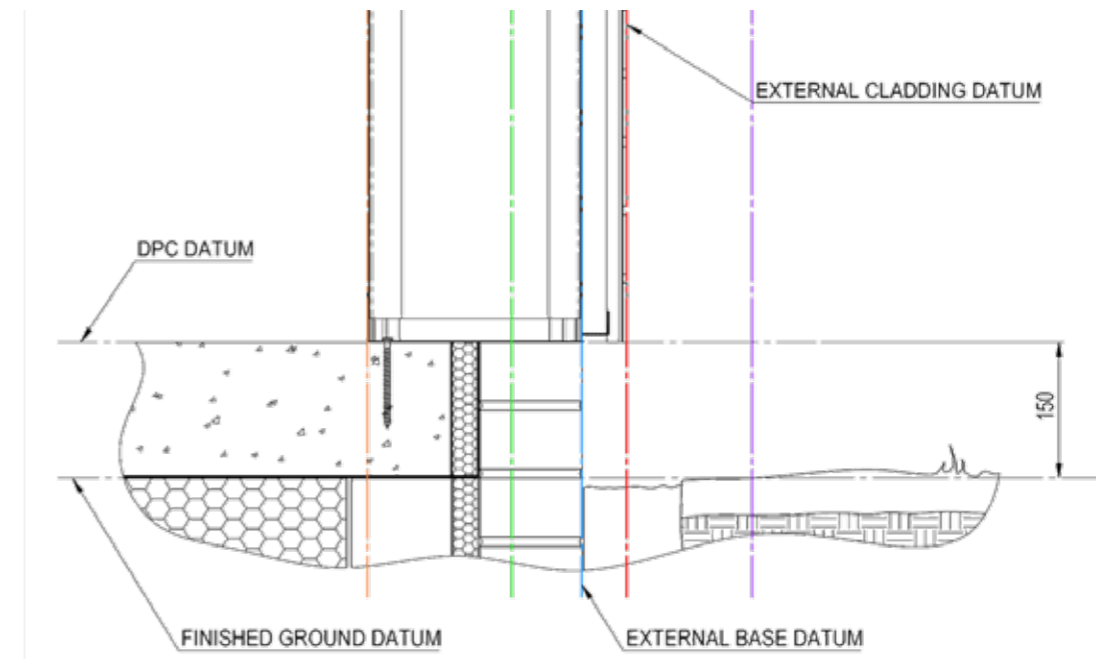

Datum lines in each diagram are indicated using different colours

- Orange ----- Internal hup! Wall Datum
- Green ----- Internal Window/Door Frame Datum
- Blue ----- External Base/External hup! Wall Datum
- Red ----- External hup! Wall Cladding Datum
- Purple ----- External Beam Soffit Overhang Datum

Please note that any outside flooring (eg decking or patio) should finish sufficiently below the DPC to stop water ingress and ensure ventilation gap behind the wall finishes. If you would like the outside floor to be level with the inside floor, you must install drainage to prevent water ingress.

Datums Glass/Hybrid Roof

Internal Frame Datum

The external face of the window or door frames lines up with the panel clips on the external base datum. With traditional 70mm frames the internal frame line sits 70mm inboard of the external base datum.

Beam Position

The inside of the eaves beam sits 70mm inboard of the external wall / external base datum. If packers are required for eaves reinforcements or the position of the internal pelmet, then wall heights will be automatically adjusted to the right height. Packers are not provided by Ultraframe.

External Fascia & Soffit

The external cornice (curved) is 241mm outboard from the internal frame line. The soffit overhang from the wall finish is 123mm.

Notes for Pricing/Specification

hup! walls are ordered to external base datums and the roof is ordered from internal frame datums. Therefore when ordering a glass or hybrid hup!, order walls to external base and deduct 70mm from each elevation to determine your roof size.

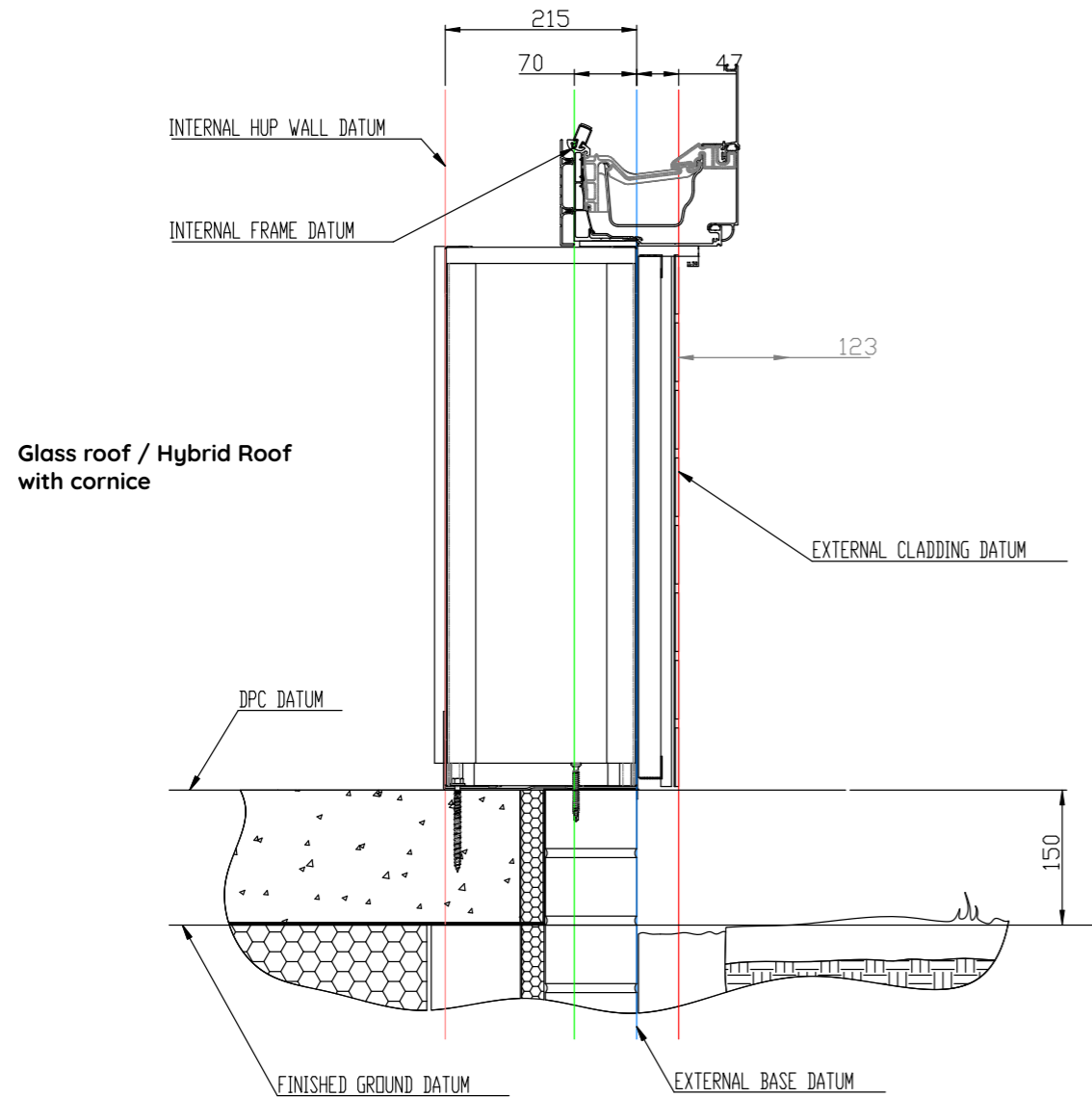

Glass Roof with Cill

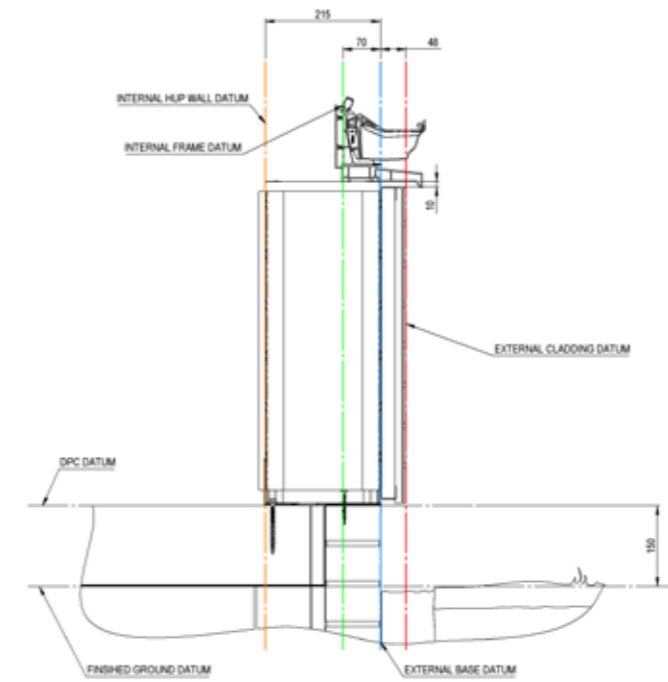

Glass Roof with heavy duty eaves

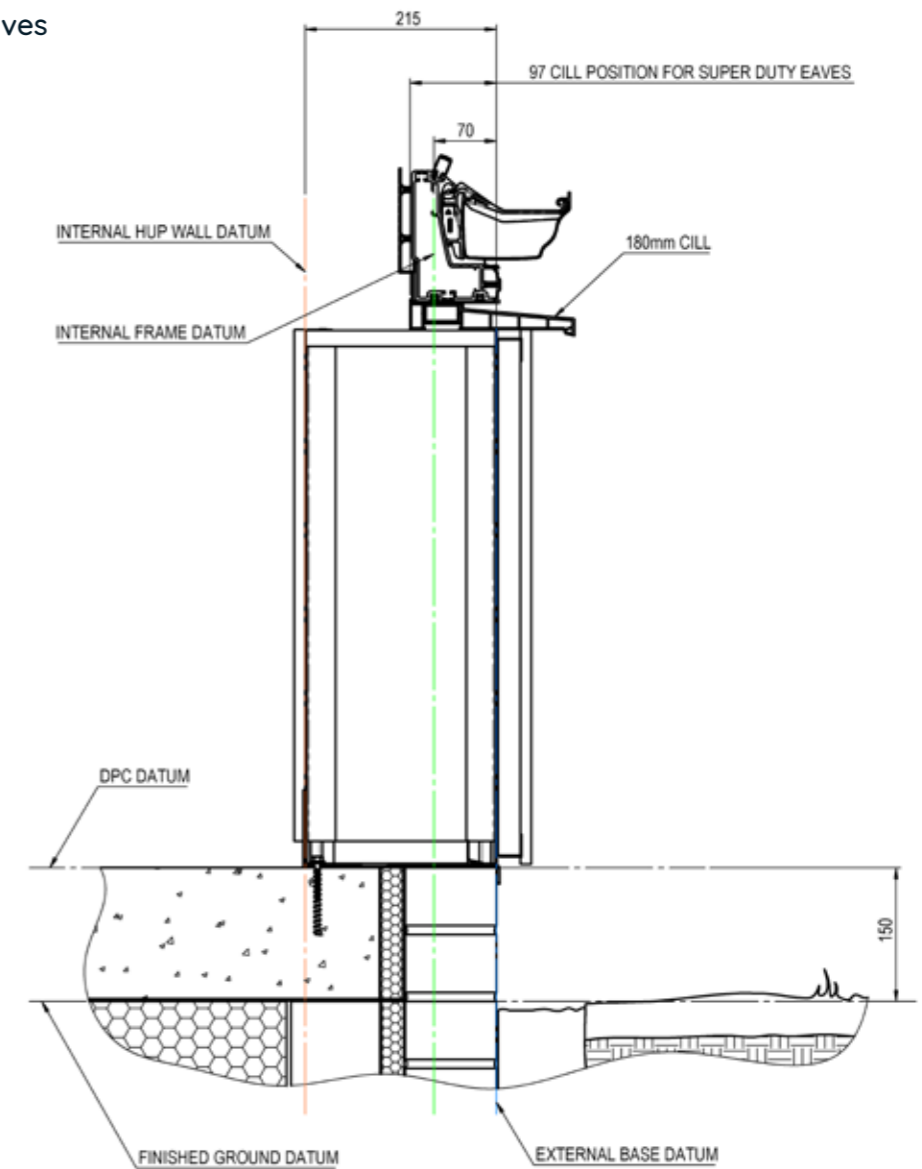

Glass Roof



The hup! Glass Roof is available for roof pitches from 2.5° to 40° and fully configurable to any shape and size. Available with a range of cornice designs, the hup! Glass Roof is also known as the Classic Roof, the UK's favourite Glass Roof system. Available in any colour, the roof system is packed full of high quality Ultraframe components such as the super-strong jack rafter, storm protection system and highly durable glazing stops and gaskets.

The Glass Roof can be supplied with a hup! mini pelmet as shown below, or the internal pelmet can be widened to up to 1200mm making it the perfect place for spotlights or speakers. You can add earthwool to the pelmet to enhance its thermal performance.



A top tray runs along the top of the hup! walls underneath the eaves beam. The clips are secured into place by fixing through the top tray. Raked frames must be used on lean-to roofs as the walls cannot be raked and meet a glass panel/ starter bar

Internally the top tray meets the edge of the internal pelmet or it can be wider.

Glass/Hybrid Roof Wall Layouts

NB: External base datums (mm) are used.

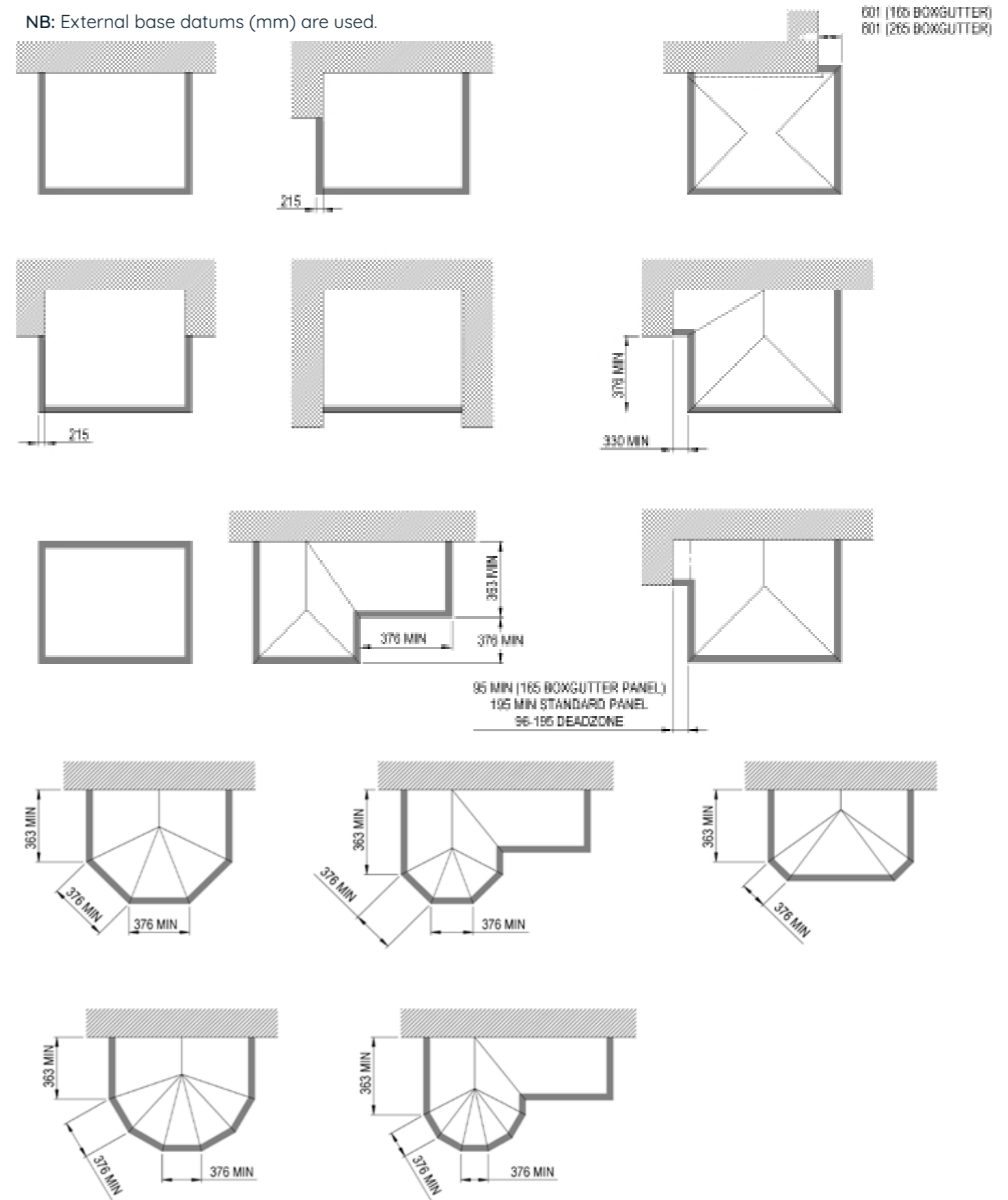

Hybrid Roof

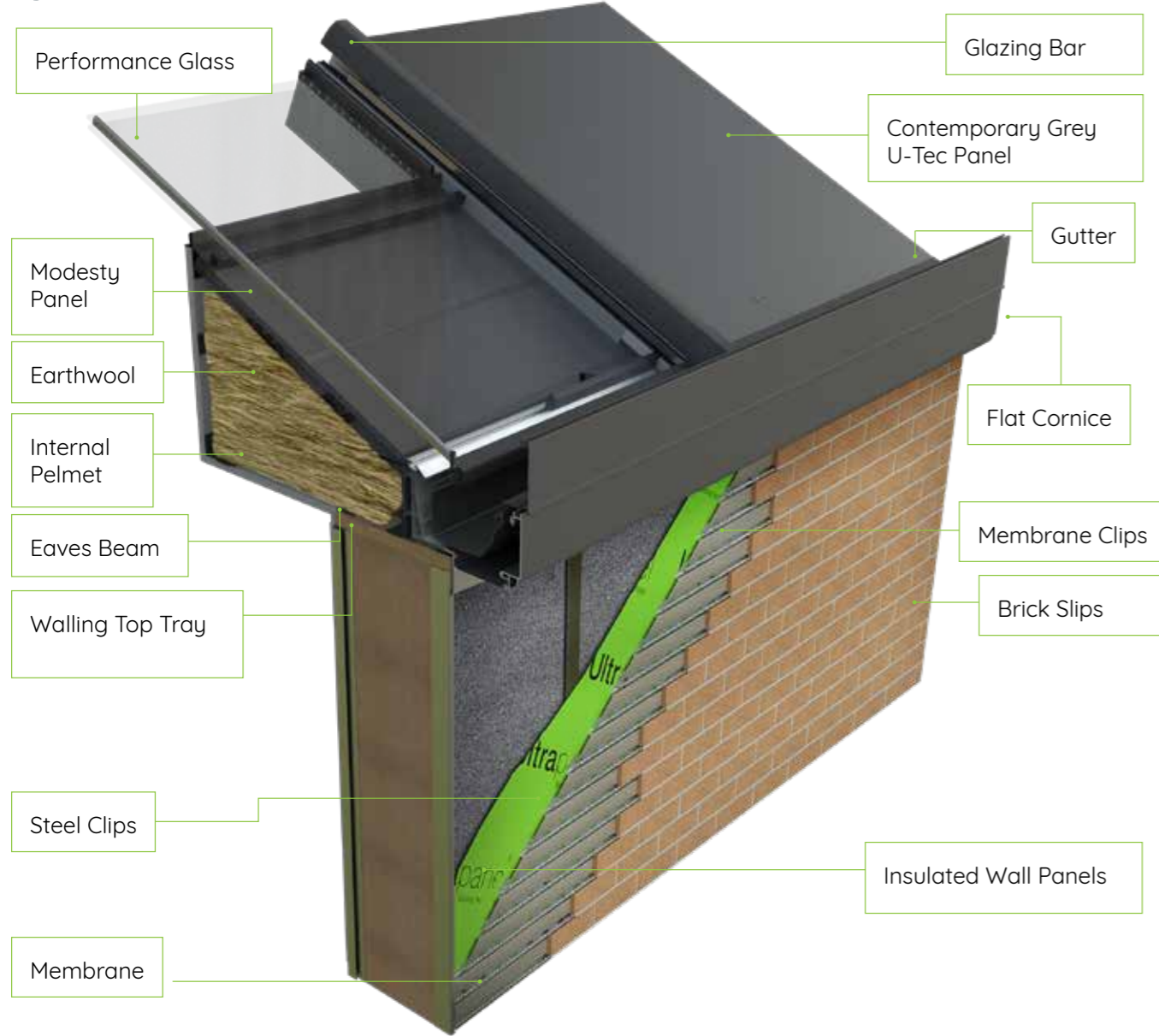

The hup! Hybrid Roof is available for roof pitches from 5° to 40° is fully configurable to any shape and size. Combining unique contemporary grey panels with rectangular or shaped glazed panels. The hup! Hybrid Roof is based on Livinroof by Ultraframe.

The pelmet in the Hybrid Roof must be a minimum of 400mm wide as shown above - this can be increased up to 1200mm. You add earthwool to the pelmet to enhance its thermal performance.



A top tray runs along the top of the hup! walls underneath the eaves beam. The clips are secured into place by fixing through the top tray. Raked frames must be used on lean-to roofs as the walls cannot be raked and meet the panels/ starter bar.

Internally the top tray meets the edge of the internal pelmet or it can be wider.

Datums Tiled Roof

Internal Frame Datum

The external face of the window or door frames lines up with the panel clips on the external base datum. With traditional 70mm frames the internal frame line sits 70mm inboard of the external base datum.

Beam Position

The inside face of the beam lies flush with the inside face of the EPS, excluding the steel clips which set the position for the beam.

External Fascia & Soffit

The external fascia of the beam is 269mm outboard from the internal frame line. The soffit overhang from the wall finish is 151mm.

Pricing/Specification

hup! walls are ordered to external base datums and roof is ordered from internal frame datums. Therefore when pricing a Tiled Roof hup!, order walls to external base and deduct 70mm from each elevation to determine your roof size. The hup! soffit is 199mm from the external base. Both these options carry a 6% premium vs the standard roof size on the pricing matrix.

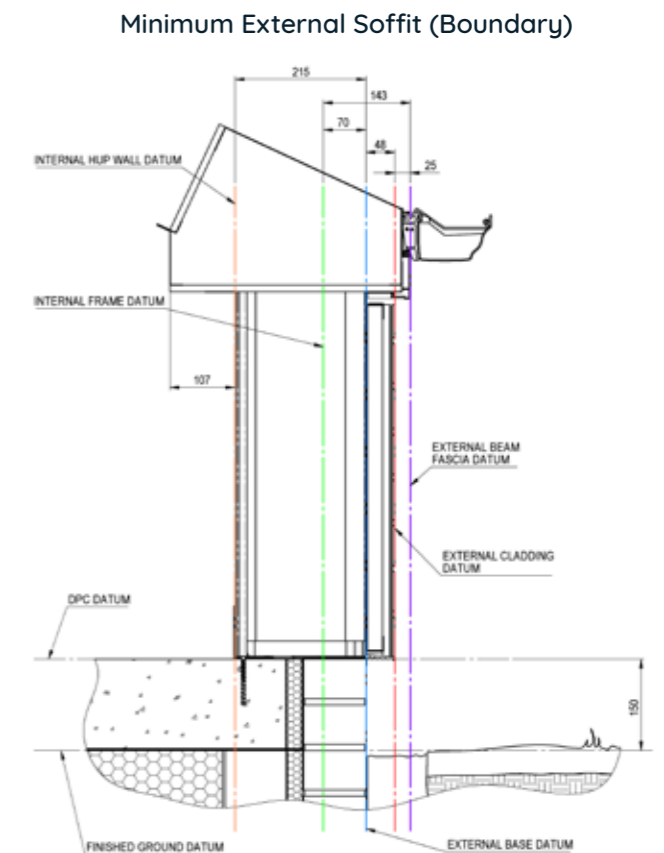
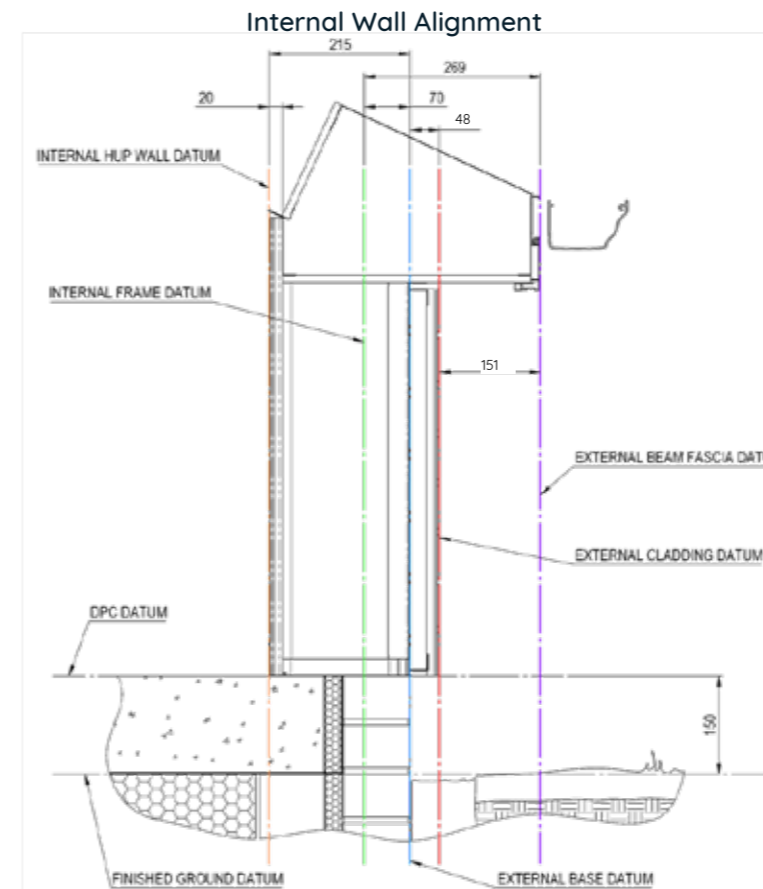

Gable/Lean to overhang with tiled roof

The diagram below shows you the dimensions of the tiled roof at gable or lean to ends.

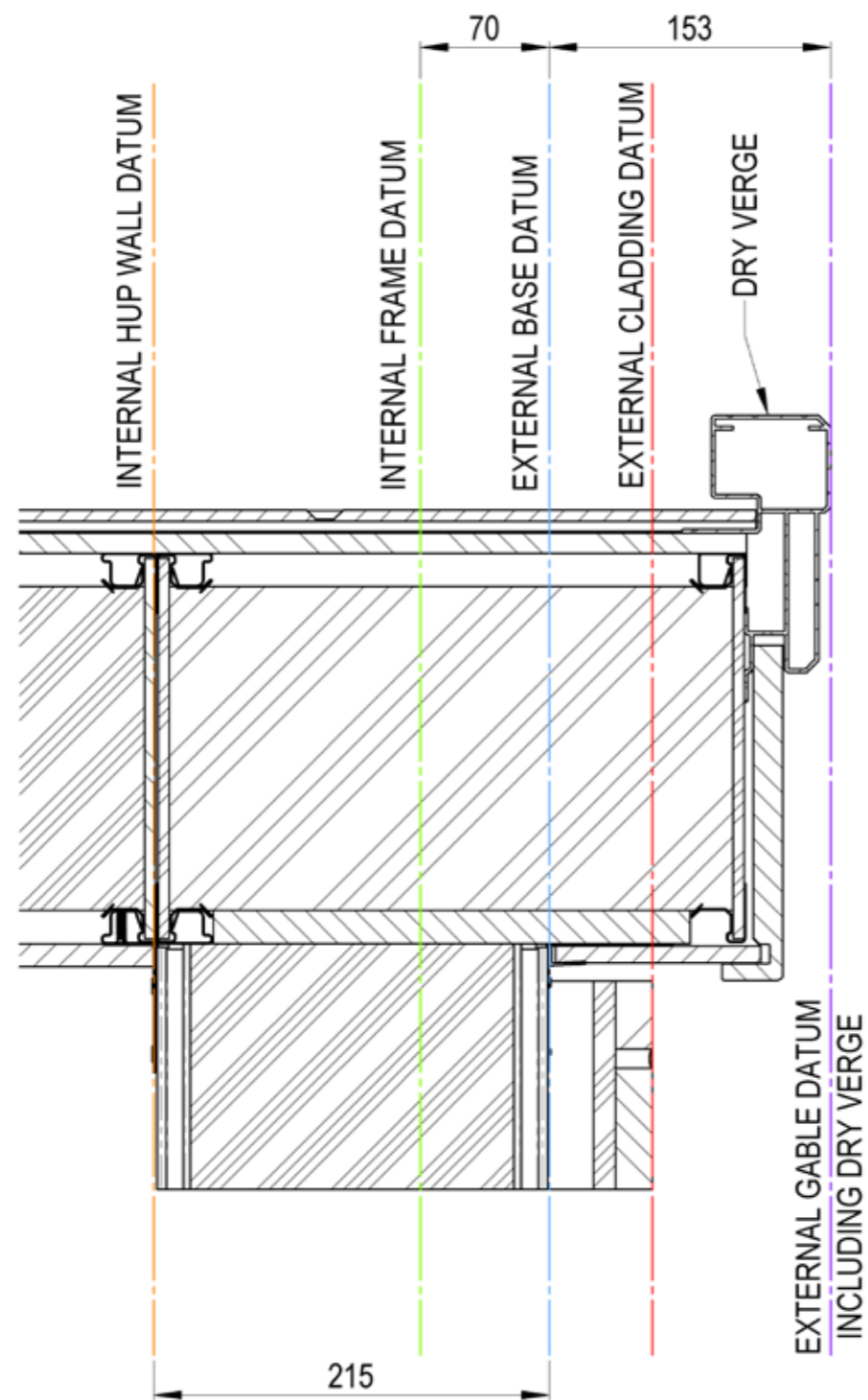

Tiled Roof

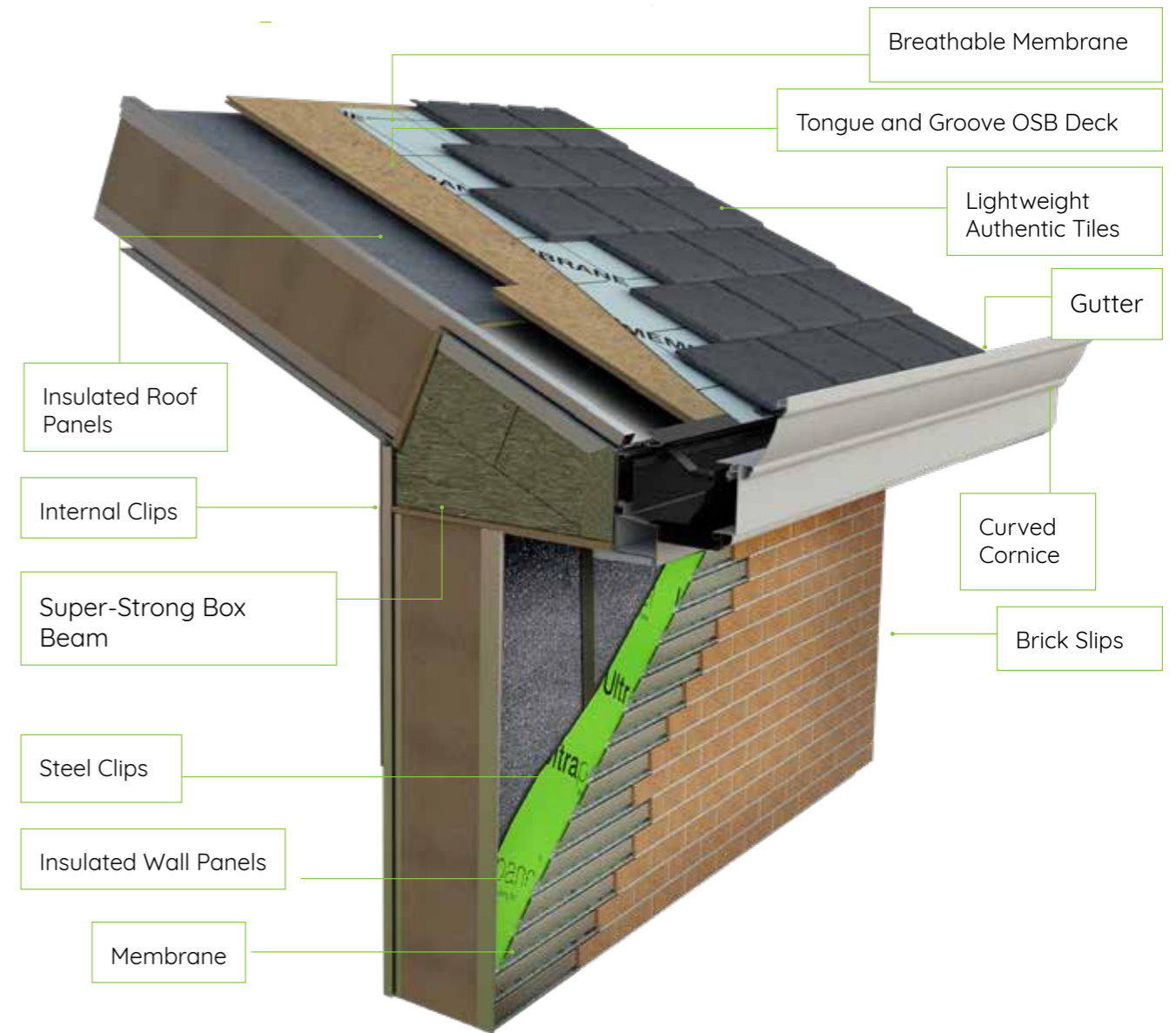

The hup! Tiled Roof is also known as Ultrarroof and does not need a tie bar like other lightweight Tiled Roof systems (although for gable roofs a high level strut may be needed). Available with a choice of full length glazing panels in a range of high performance glass or conventional Velux windows, the roof can accommodate door spans of up to 4m with no need for extra structural support.

Ultrarroof is available with 3 shades of lightweight tiles or can also be used with slate or concrete tiles too.

The hup! Tiled Roof is available in lean-to, hipped lean-to, gable, Georgian, double hipped Georgian, L-shape and T-shape with a maximum width of 6780mm and projection of 5000mm. See process guide page for maximum sizes by roof shape.



The clips run up the back of the internal side of the beam and are screwed into the steel beam section.

The clips are attached with small angle brackets to the front of the beam. These sit on the outside of the clip and are screwed to the underside of the OSB.

Please note the -190mm soffit option is not available with hup!. The external of the clip to the edge of the beam is 199mm including fascia board.

Tiled Roof Wall Layouts

NB: Please note external base datums (mm) are used.

* Minimum ridge lengths apply.

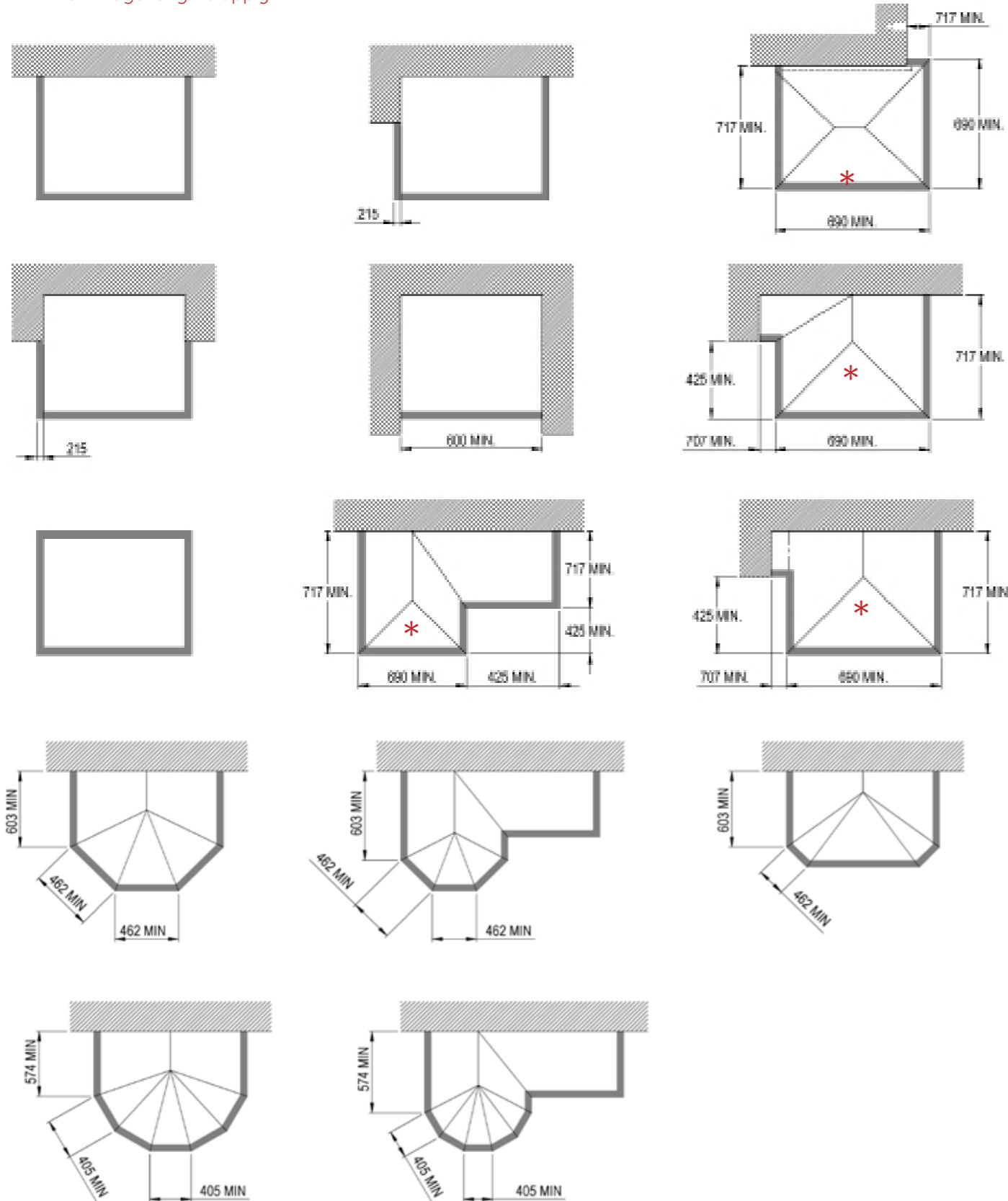

Datums Flat Roof

Internal Frame Datum

The external face of the window or door frames lines up with the panel clips on the external base datum. With traditional 70mm frames the internal frame line sits 70mm inboard of the external base datum.

Beam Position

The inside face of the beam lies flush with the inside face of the EPS, excluding the steel clips which set the position for the beam.

External Fascia & Soffit

The external fascia of the beam varies dependent on specification. The soffit overhang from the wall finish is shown below as dimension A.

Pricing/Specification

hup! walls are ordered to external base datums

and roof is ordered from the external beam face. Therefore when ordering a Flat Roof hup!, order walls to external base and deduct 19mm from each elevation to determine your roof size.

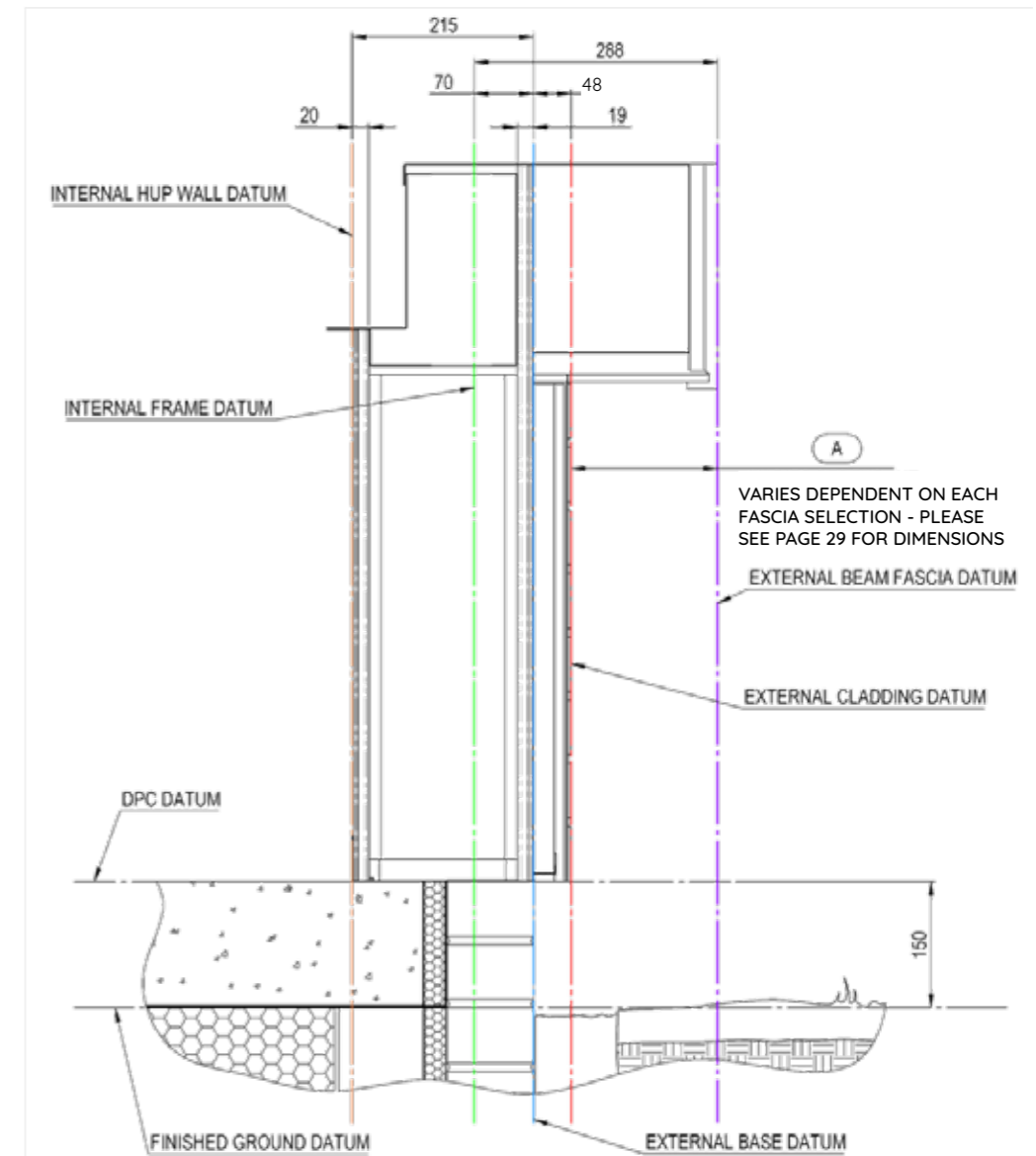

Flat Roof



The hup! Flat Roof system is available in rectangular shapes up to 4m projection and 7m wide. With all structural calculations taken care of in one easy order the hup! Flat Roof can accommodate 0,1 or 2 apertures and supplied with lanterns or flat skylights as required.

Whether ordered separately or with hup! the Ultraframe Flat Roof uses the base datum for ordering and pricing purposes. With hup! the clips run up the front face of the beam and clips protrude by 19mm and with wall finishes the external wall face sits 48mm outside the base datum.



Externally the clips run up the outside of the beam behind the fascia.



Internally the clips meet the beam shelf.

Flat Roof Wall Layouts

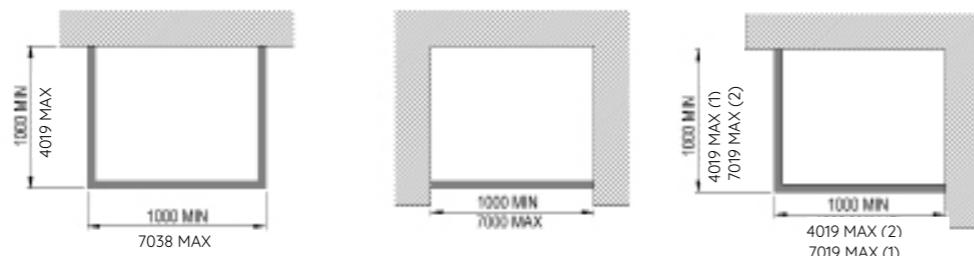

Flat Roof Soffit Sizes

Because the wall panel clips run up the front of the beam and the external wall finishes 48mm beyond the clips, the soffit sizes are smaller with hup! than if used with traditional brick.

Claddings can also run up the front face of the beam giving the impression of a slimmer roof deck.

Standard Soffit	Extended Soffit
Classic Fascia	Extended Soffit
Curved Cornice Fascia	Curved Cornice Fascia
2 Tier Cornice Fascia	2 Tier Cornice Fascia
<p>INTERNAL HUP WALL DATUM</p> <p>INTERNAL FRAME DATUM</p> <p>EXTERNAL BEAM FASCIA DATUM</p> <p>A = External cladding to external soffit.</p>	

Large Door Sets / Unsupported Spans

There are two forces that need to be considered if large doors are to be used within the hup! design.

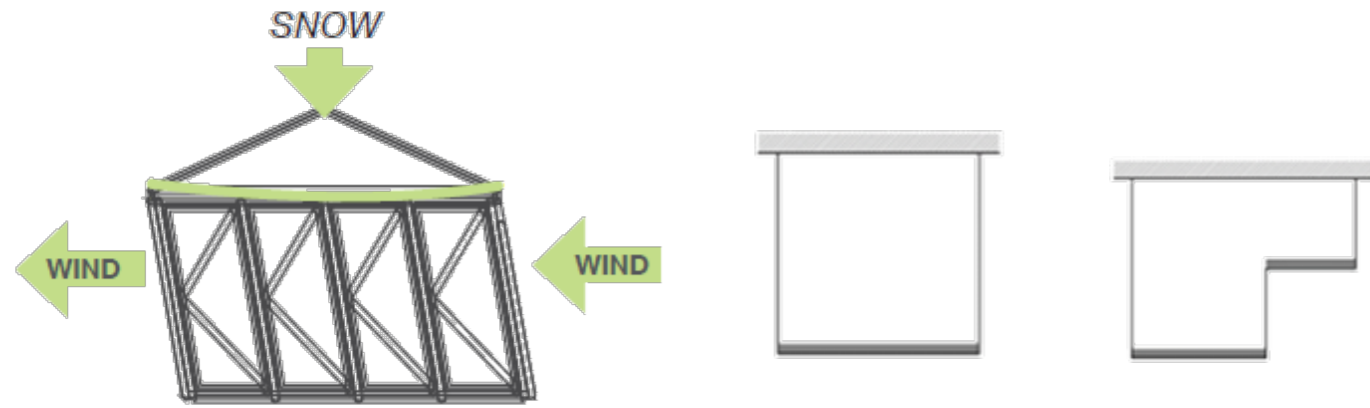

Downward, vertical forces (e.g. snow) need to be managed to prevent doors from sticking and lateral forces from side winds need to be managed to prevent the building from racking.

Managing Vertical Forces

The eaves beam of the roof system chosen for your hup! needs to be strong enough to support the vertical forces. Refer to the specification guide of each roof system to determine the spanning capability of the system. The table below is a guide to help you. If your design needs a greater span than the roof system allows, goalposts can be used with hup! and are available from Ultraframe, price on application.

Roof System	Door Span Guidance
Glass Roof	Choose from a range of eaves reinforcements and goalposts to find the most cost effective solution to support the door span required up to 6m.
Hybrid Roof	
Tiled Roof	Spans up to 4m over doors.
Flat Roof	Max door span on front elevation is 5.6m and on side elevation 5.2m. This depends on roof configuration.

Managing Lateral Forces

When building with hup! like any extension, it is essential that lateral stability is considered. If large door spans are required in the elevation parallel to the host wall, the following options should be considered either side of the opening:

- Reinforced hup! corner: Standard hup! corner post is 300mm by 300mm with an integrated reinforced post on the outside which has no impact on overall dimensions. The post is visible on the lower courses of brick below DPC.
- 665mm wide hup! corner: this is a standard hup! corner + 335mm panel either side and requires no additional reinforcement.
- 500mm window return.
- Structural post : A minimum of 100 x 100mm structural post is required.
- Goalpost: If the roof requires a goalpost to support the doors below, a goalpost can also be used to provide lateral stability. The goalpost will sit inside the walling system and therefore needs to be boxed off or powder coated.

Structural Post (Lateral Stability)

The hup! walls are configured to ensure that lateral stability is considered. To achieve this, the minimum distance of an opening from a corner is 665mm which can be achieved with either walling or fixed frames. It is possible to reduce this to 275mm and 375mm (300mm and 400mm to the outside of the timber batten) using the hup! corner as shown in the diagrams below, with the specification of a structural steel set out post which runs up the outside corner of the base. Please note that the painted (grey) post is visible locally at the corner of the courses of brick below DPC.

In order to ensure the building is laterally stable, hup! software will automatically insert a reinforced column based on dimensions of openings and size of build.

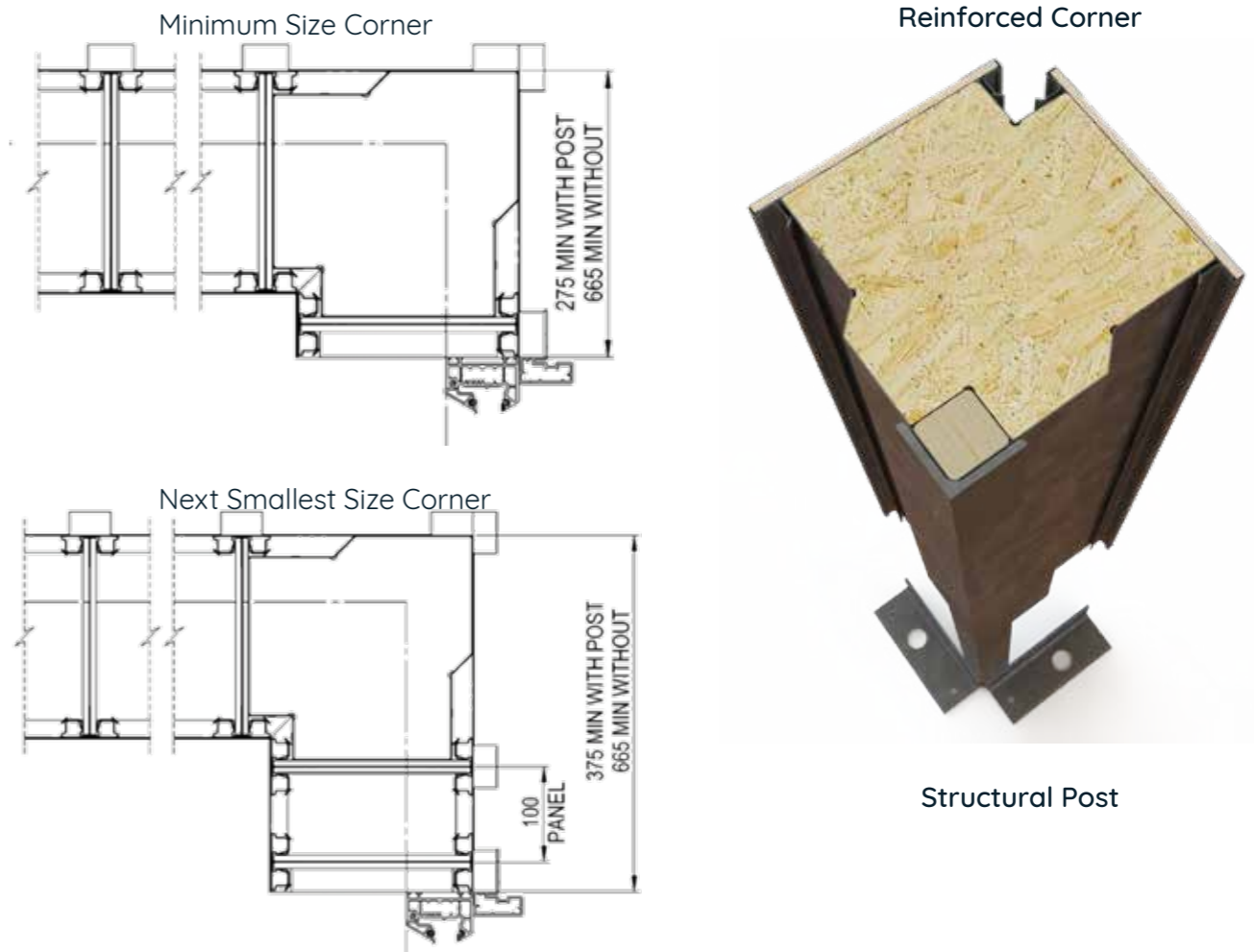

When there are openings on either side of a non 90° corner and one of the openings is on an elevation which is parallel to the host wall, the hup! corner requires a minimum of 375mm either side of the corner to ensure lateral stability.

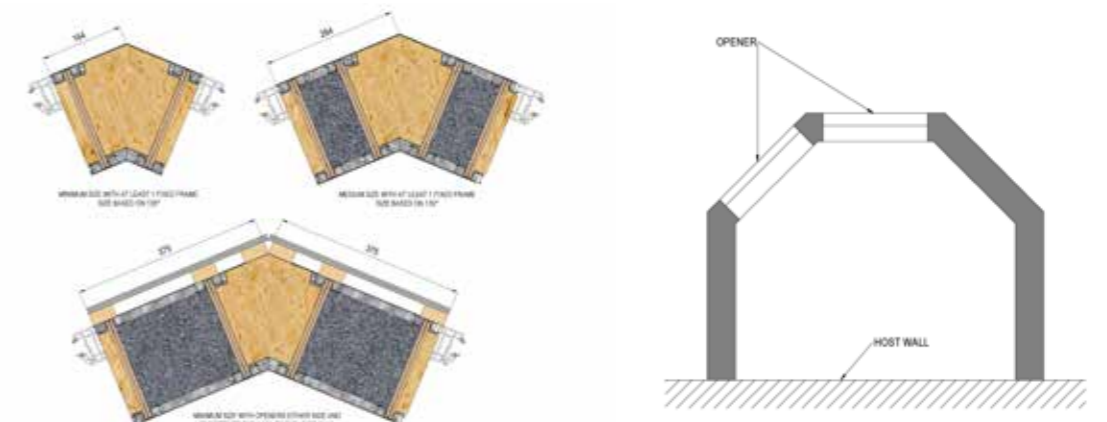

Internal corners

On hup! corners there are 3 situations and dimensions for internal corners. See below the different options.

Minimum wall return with aperture between piers

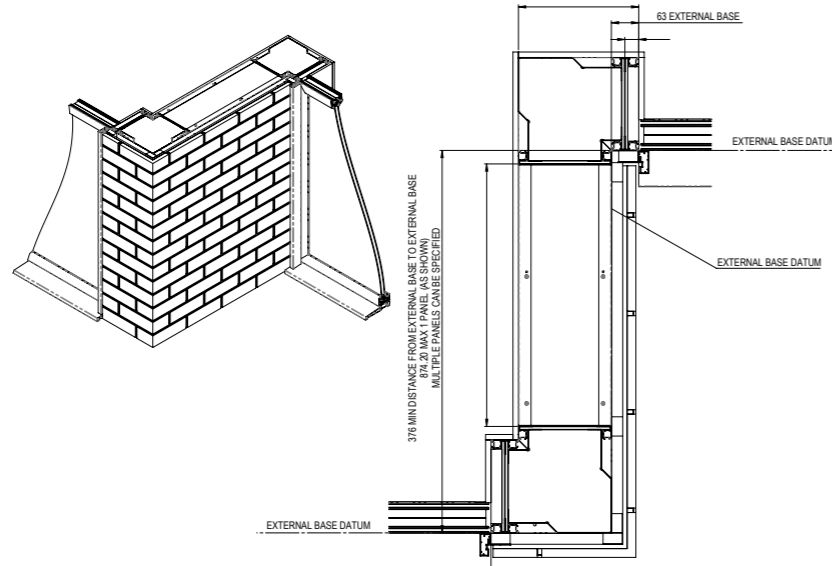

Minimum wall return - solid between apertures

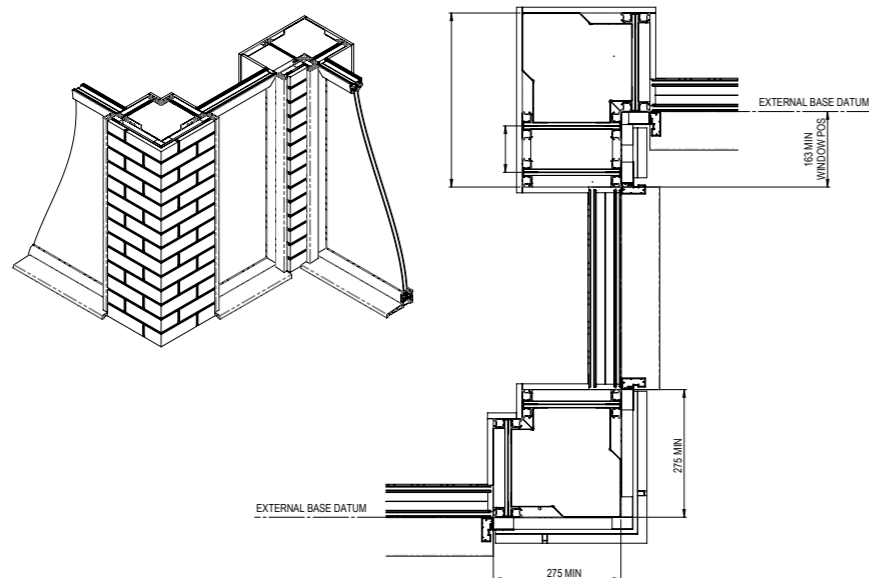

Minimum wall return - solid no apertures

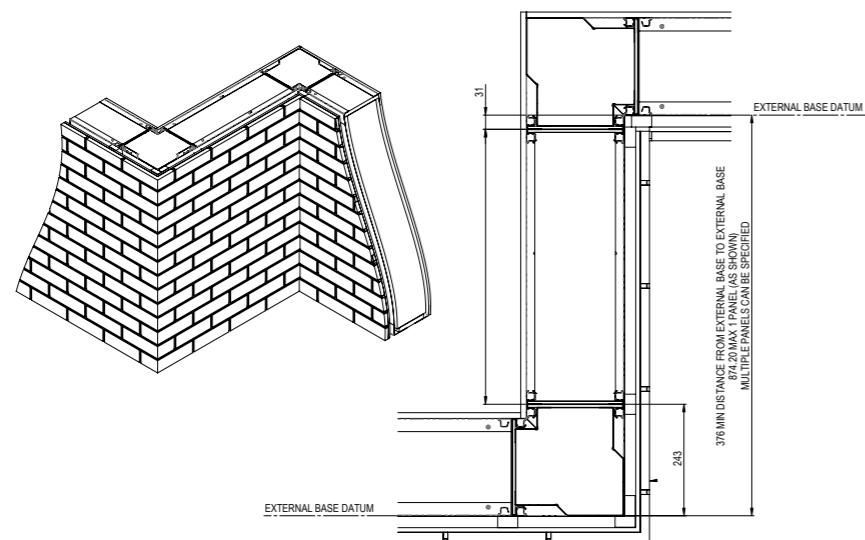

Gable Frames

When gable frames are specified with hup! walling, there are different finishing conditions dependant on the chosen roof system. This is applicable to full ridge gable ends and lean-to's.

Glass or Hybrid Roof (with Cornice)

When Cornice is specified on a Glass or Hybrid hup!, the Cornice wraps around the gable end up to the gable frame.

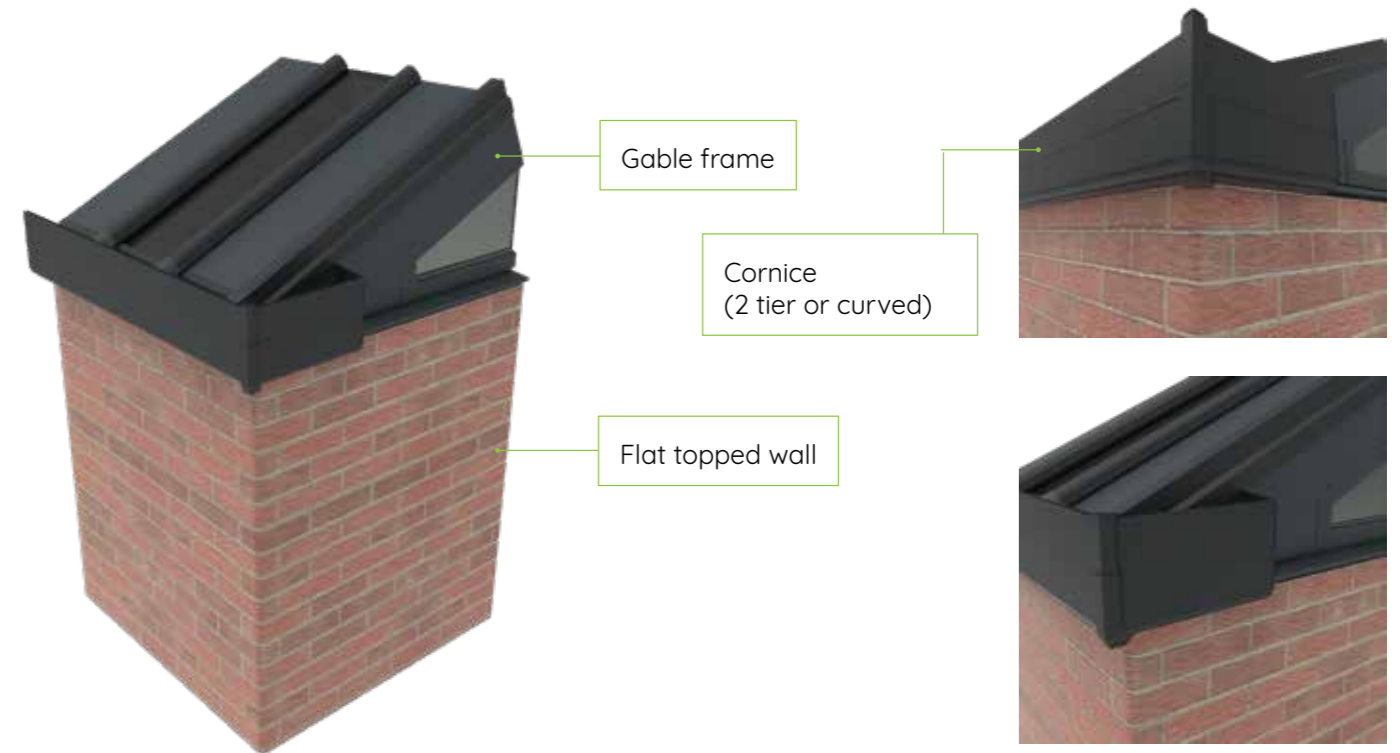

Glass or Hybrid Roof (on Cill)

When Cornice is not specified, the top of the walls are closed off with a cill (not supplied).



Gable Frames

Tiled Roof

When specifying a gable tiled Hup!, the walling returns around the corner (following the minimum corner rules) and runs into the underside of the roof.



Minimum Corner Rules

Minimum corner rules apply but can be reduced by specifying a structural post. See lateral stability section.

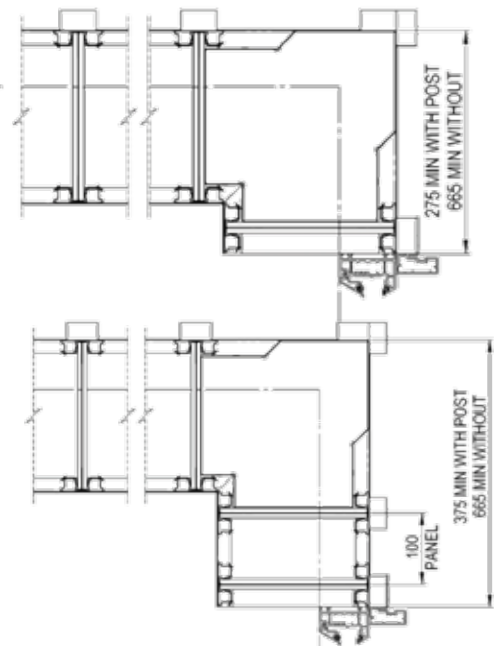

High Level Structural Strut

The gable tiled hup! is supplied with a high level strut (matt white) to resist the spread of the roof.

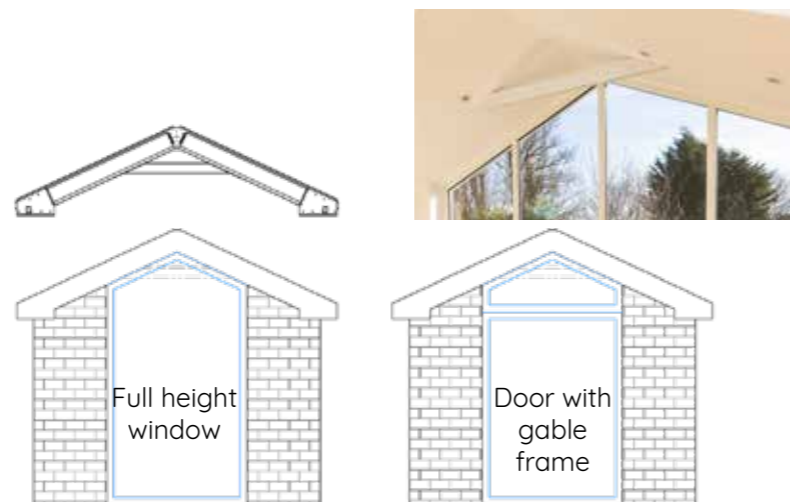

Frequently Asked Questions

Is planning permission required?

Check with your Local Authority and the Planning Portal.

Is Building Control approval required?

Check with your Local Authority and the Planning Portal.

What if my extension is close to the boundary (Fire)?

Within 1 metre of the boundary, the hup! wall is required to be fire rated to 30 minutes. The hup! walls have been tested using the calcium silicate board to achieve the required 30 minutes. Claddings with a fire rating of less than Class B, S3, D2 should never be used on a boundary even with calcium silicate board, if specifying your own cladding. The relevant fire testing certification will be required for Building Control.

When you build within 1-2 meters away from a boundary line, you are only allowed 5.6sq2 of unprotected area. Please refer to Building Control document Part B, for unprotected area calculations when further away than 1 metre.

What if my extension is close to the boundary (access)?

If the hup! extension is close to a boundary, either allow enough access between the side wall and the boundary to enable fitting and cladding, or consult with the neighbouring property to allow access during this stage of installation. Alternatively hinge can be provided to manoeuvre hup! boundary wall into place.

How secure is hup! ?

If using brick slips, or a rendered finish, the external face of the walls are lined with calcium silicate board beneath the external cladding. This creates a robust external barrier which is incredibly difficult to penetrate. Windows and doors are secured to aperture panels which carry 25mm OSB to ensure fixings are robust.

Why is the trunking horizontal not vertical?

The horizontal trunking is run at a set height of 450mm above floor level to cater for sockets, giving space for back boxes. The main benefit of the trunking is to enable the cables to easily be run across the wall behind the steel clips without the requirement to batten out the inside of the wall, as a hole can be made in the hardboard panel sides to pass the cable between panels. Cabling however can be run vertically in conduit to avoid contact with the EPS.

Can the trunking be used for water pipes?

Electrical cables and piping should not be run together in the trunking. If using the trunking for water pipes, the cable can run around the perimeter of the eaves and dropped down the panel in conduit.

How do we prevent the heat from a radiator affecting the wiring?

If cable is in the trunking, any pipework should run behind skirting as shown in the Specification Guide in rebated skirting boards. The cabling should not be directly affected by heat from radiators as it will be separated by plasterboard as it would with a stud or block wall.

To what extent do hup! walls let in noise from outside?

The make up of the hup! wall includes a combination of material densities resulting in excellent sound absorption.

What is the maximum cladding thicknesses I can use on hup!?

The hup! system is capable of accepting the following cladding thickness dependant on roof system (see table) and weights of up to 45kg/m².

- Flat Roof (Standard) - 23mm*
- Flat Roof (Extended and 4 Tier Cornice) - 160mm*
- Ultrarroof - 110mm*
- Ultrarroof Standard Gable End - 30mm* (Extended Soffit will increase this)
- Glass Roof /Hybrid Roof (Any Cornice) - 35mm*
- Glass Roof /Hybrid Roof (150mm Cill) - 23mm* (increasing cill size will increase possible cladding depth)

*All dimensions are from the outside of the calcium silicate board. Please note that roof soffits may be concealed if using the maximum thickness cladding and therefore would prevent the use of external downlights.

Can I paint the Calcium Silicate board, especially if using your boundary wall solution?

If customer want to use a paint on their boundary wall we would suggest the Emperor Exterior Wall Protection paint. It has a lifetime guarantee and costs £52 for 5 litres.

We would suggest they paint the Calcium Silicate board, boards in a warehouse or somewhere under cover individually then leave to dry. Once dry they can be assembled into a wall and hinges into place using our boundary wall hinge solution.

<https://emperorpaint.co.uk/exterior-wall-protection>

How long can I leave the Calcium Silicate board without rendering it? For example if it is too wet or cold to render. 12 months

Can I install external sockets and lighting?

When installing outside sockets or lighting then the cable can be fed through the walling system to the required position, see page 26. With all electrical installation work that you use a registered / certified electrician that can supply Part P certification.

Frequently Asked Questions

Are boiler flues allowed with hup!?

Boiler flues can go through our roofing and walling systems, we need to know the exact position so we can ensure that the flue does not interfere with the main structure.

Specification of boiler flues / flue extension kits?

The specifications of flue extension kits or any works to the boiler, please contact a Gas Safe engineer for further advice and compliance.

What are the regulations around boiler flue?

At one time you could put your boiler almost anywhere in your home, but these days the regulations are very strict on where you can and can't position your boiler and flue. The regulations around boiler flue position are necessarily strict to prevent deaths, and any party who fails to adhere to them can face serious consequences.

Boiler flue separation distances

Please note that the following are the separation distances for fan-assisted room-sealed appliances. Natural draught-balanced flues and open flues have different required dimensions.

The positioning of the flue needs to be (a minimum of):

- 300mm away from an opening window or air vent
- 25mm below guttering, drain pipes or soil pipes
- 300mm above the ground, roof or balcony level
- 2,000mm below a Velux window
- 1,200mm from an opening, such as a door or window, into the home
- 2.1m off the ground if it faces a public space such as a pavement
- If on a ground floor wall, a grill or metal box is required to cover the flue

How do I know if the existing base is suitable for hup!?

Building Regulations stipulate that you should not add more than 15% of extra loading to a base if renovating a conservatory.

hup! is lightweight and rarely adds more than 15% to the loading on an existing conservatory base, so as long as the existing base is sound, it will be suitable for use with hup!

You should check for signs of movement, cracking or instability of the current structure before making a your declaration that the base is suitable on your Building Regulations application that you believe the base is fit for purpose.

If you are unsure and need to do a test dig, a strip

foundation must be at least 450mm deep with 150mm of concrete.

How do I insulate an existing base if I am using hup!?

You have 50mm to play with including the insulation and floor finish. Using a threshold this could be increased to 70mm, but the height of any existing internal doors would need to be considered. There are many floor insulation options on the market, but here are a few we recommend.

Tiled floor on existing base

You can choose Pro-Warm Tile backer which is available in 6mm (U-value 5.5W/m2K), 10mm (U-value 2.62W/m2K) 12.5mm or 20mm (U-value 1.65W/m2K) and 30mm (U-value 1.1W/m2K)

Other floors on existing base

Eco-tec floor foam is only 6mm thick, or if you can use a threshold and want to be Building Regulation compliant you could use two Kingspan products:

1. Kingspan TF70 which has a U-value of 0.55W/m2K (insulation only) and is 40mm thick +18mm chipboard. Any floor finish would need to be less than 12mm, to come in less than 70mm
2. Kingspan Optim R 20mm which has a u-value of 0.25W/m2K as a floating floor which can be used with a floating floor like laminate or used with a Fermacell 15mm board to adhere other finishes to.

I am concerned about the new hup! Base bouncing, is the base suitable for tiling? Will it crack?

hup! Base has less movement than a normal floor with joists (e.g. second floor bathroom). The surface should be prepared in accordance with the manufacturers instructions.

Is the hup! Base strong enough for a really heavy object (e.g. heavy fish tank)

Yes but if you wish to be on the safe side you can let us know and we will ensure the framework is constructed to put support where you need it.

Understanding the Order Confirmation

Here is a worked example of a hup! with a tiled lean-to roof. The following documents will be issued as part of the order confirmation. This is what the extension looks like when built. The utility room is located below the single glazed roof panel. The internal walls are stud walls, not hup!.



This shows a 3D representation of the hup! from all sides. A single glazed roof panel lights the utility room, and bi-fold doors and a double glass roof panel provide plenty of natural light into the lounge. Both boundary walls are solid with no windows. White gutters and roof trims have been chosen.

COMPANY NAME :	MANUFACT DATE :	DATE DRAWN :
ACCOUNT CODE :	DESPATCH DATE :	CONFIG NUMBER :
CUST REFERENCE :	DELIVERY DATE :	DRAWN BY :
CUST TELEPHONE No :	CUST FAX No :	SITE POSTCODE :
Ultraframe Wall Options		
Wall Finish & Thickness	Customer Supplied	8 mm
Timber Battens & Depth	Ultraframe to Supply	28 mm
Render Board & Thickness	Ultraframe to Supply	12 mm
Aperture Trim	Ultraframe to Supply	
Ventilation Trim	Ultraframe to Supply	
Cable Management	Ultraframe to Supply	
Add Soldier Courses	No	28mm
Cavity Base Tray	Standard Base Tray accommodates base cavity wall up to 275mm	
Customer must ensure finish/batten/render thickness is correct, otherwise the external wall sizes will be wrong		
Coloured Parts List		
Wall Finish	Customer Supplying	
Aperture Trim Colour	Smooth Grey	
External Roof Colour	White	
Gutter Colour	Black	
Wall Finish Dimensions		
Total Wall Area - 8.388m ²		
Total Corner Length - 4.200m		
Total Aperture Edge Length - 7.200m		

Finishes Report

The top half of this report confirms details of the wall kits including the dimensions of each 'layer'

The bottom half shows exactly what colours have been chosen for the 'coloured elements of the entire hup! project to help you understand exactly what will be provided, helping you to avoid any unexpected mismatches.

hup! - A Building Revolution from Ultraframe

trade-hup.co.uk

Job No. 9055 Code: HUG002 hup! Spec Guide 03/26
It is Ultraframe's policy to continually seek to improve its products, processes
and services and we reserve the right to change specifications without prior notice.
We have been trading for over 35 years and strive to deliver unrivalled quality and service.